



# 用户手册

## User Manual

中文: [www.gboslaser.cn](http://www.gboslaser.cn)  
English: [www.gboslaser.com](http://www.gboslaser.com)



**中国智能化激光系统领导品牌**  
CHINESE LEADING BRAND OF INTELLIGENT LASER SYSTEM

感谢购买 GBOS LASER(光博士激光)产品,  
在使用本产品之前,请仔细阅读本说明书,并保存以供参考;  
本说明书中的图示仅为示意图。

Thanks for choosing GBOS LASER products,  
Before using, pls read the user manual carefully and keep it for reference;  
The pictures in this manual are only schematic diagram.



售后服务热线: 400-6677-328  
**东莞市光博士激光科技股份有限公司**  
GBOS LASER INC.

生产基地: 广东省东莞市东城区同沙科技园  
production base: tongsha scien-tech industrial park dongcheng  
dongguan city guangdong province

市场总部: 广东省东莞市东城区同沙科技园太初坊村(松山湖大道旁)  
Headquarter: Taichufang Village TongSha Scien-Tech Industrial Park  
DongGuan City GuangDong (By SongShan Lake Road)

国内销售部 [Domestic office]: 0769-88990166 89972888(30线)  
传真 Fax: 0769-89972868 E-mail: [ceo@gboslaser.com](mailto:ceo@gboslaser.com)

[Export office]:

Tel: 0086-769-88990609  
Fax: 0086-769-88990677 E-mail: [gbos@gboslaser.com](mailto:gbos@gboslaser.com)  
Add: 2-1014, TBA Tower, Dongguan Blvd., Dongguan City,  
Guangdong, China. P.C: 523000

**GN SERIES**  
HIGH PRECISION

**GH SERIES**  
HIGH SPEED

# 目录

声明.....	5
<b>第1章 序言</b> .....	7
1.1 欢迎.....	7
1.2 公司简介.....	7
1.3 保修条款.....	7
<b>第2章 安全说明和预防措施</b> .....	8
2.1 综述.....	8
2.2 激光安全通告.....	9
2.2.1 眼和皮肤的保护.....	9
2.2.2 防火保护.....	9
2.2.3 电气安全.....	10
2.2.4 材料安全通告.....	10
2.2.5 机器的防护措施.....	10
2.2.6 使用人员常识.....	10
<b>第3章 产品的概述</b> .....	10
3.1 产品的主要型号.....	10
3.2 产品特点及外观图.....	11
3.3 型号定义说明.....	12
3.4 主要用途及适用范围.....	12
3.5 使用环境条件.....	12
3.6 对环境及能源的影响.....	13
3.7 工作原理.....	13
3.7.1 控制系统.....	13
3.7.2 主机模块.....	13
3.7.3 光学系统.....	14
3.7.4 工作台.....	15
3.7.5 排风系统.....	15
3.7.6 冷却系统.....	15
<b>第4章 安装、调试</b> .....	16
4.1 交货检查.....	16

4.1.1 开箱注意事项.....	16
4.1.2 检查内容.....	16
4.2 安装环境要求.....	16
4.3 安装方法及注意事项.....	17
4.3.1 校水平.....	17
4.3.2 水箱连接.....	17
4.3.3 风机电源线连接.....	18
4.4 调试方法及注意事项.....	18
<b>第 5 章 使用须知.....</b>	<b>19</b>
5.1 使用前的准备和检查.....	19
5.2 整机开机程序.....	19
5.3 整机关机程序.....	19
<b>第 6 章 维护、保养和故障排除.....</b>	<b>20</b>
6.1 综述.....	20
6.2 日常维护、保养.....	20
6.2.1 风机检查和维护.....	20
6.2.2 光学系统检查和清洁.....	20
6.2.3 水箱的检查和维护.....	21
6.2.4 电气检查.....	22
6.2.5 激光保护装置的检查.....	22
6.2.6 检修周期.....	22
6.3 故障分析及排除方法.....	22
6.3.1 激光能量弱;.....	22
6.3.2 运行不出光, 测试出光正常;.....	22
6.3.3 机器无论测试或加工均不出光.....	23
6.3.4 机器一个或多个方向不能动作;.....	23
6.3.5 机器不通电.....	24
6.3.6 机器运行时轨迹有明显锯齿.....	24
<b>第 7 章 技术规范.....</b>	<b>25</b>

## Contents

<b>Statement.....</b>	<b>26</b>
<b>Chapter 1 Preface.....</b>	<b>28</b>
1.1 WELCOME.....	28
1.2 COMPANY PROFILE.....	28
1.3 WARRANTY CLAUSES.....	28
<b>Chapter 2 Safety Instruction and Preventive Measures.....</b>	<b>29</b>
2.1 Review.....	30
2.2 Laser safety notice.....	30
2.2.1 PROTECTION OF EYES AND SKIN.....	30
2.2.2 FIRE PROTECTION.....	30
2.2.3 ELECTRICAL SAFETY.....	31
2.2.4 SAFETY NOTICE OF MATERIAL.....	31
2.2.5 PROTECTIVE MEASURES OF EQUIPMENT.....	31
2.2.6 GENERAL KNOWLEDGE FOR USER.....	31
<b>Chapter 3 Product Overview.....</b>	<b>32</b>
3.1 Main models of product.....	32
3.2 Product characteristics and external view.....	32
3.3 Model instruction.....	33
3.4 Main application and scope of application.....	33
3.5 Operation environment.....	33
3.6 Impact on environment and energy.....	34
3.7 Working principle.....	34
3.7.1 Control System (See Operation Instruction Of Control System).....	34
3.7.2 HOST MODULE.....	34
3.7.3 OPTICAL SYSTEM.....	36
3.7.4 WORKBENCH.....	36
3.7.5 EXHAUST SYSTEM.....	36
3.7.6 COOLING SYSTEM: (SEE FIGURE BELOW).....	36
<b>Chapter 4 Installation and Debugging.....</b>	<b>37</b>
4.1 Delivery inspection.....	37
4.1.1 PRECAUTIONS OF UNPACKING.....	37
4.1.2 INSPECTION CONTENT.....	38

4.2 Requirements of installation environment .....	38
4.3 Installation method and precautions.....	38
4.3.1 LEVELING .....	38
4.3.2 CONNECTION OF WATER TANK .....	39
4.3.3 CONNECTION OF FAN/POWER CORD .....	39
4.4 Debugging method and precautions .....	40
<b>Chapter 5 Notice for Use.....</b>	<b>40</b>
5.1 Preparation and inspection before usage .....	40
5.2 Startup program of machine .....	41
5.3 Shutdown sequence of machine .....	41
<b>Chapter 6 Maintenance and Troubleshooting .....</b>	<b>42</b>
6.1 Overview .....	42
6.2 Daily maintenance.....	42
6.2.1 CHECKING AND MAINTENANCE FOR SUCTION FAN .....	42
6.2.2 CHECKING AND CLEANING FOR OPTICAL SYSTEM .....	42
6.2.3 CHECKING AND MAINTENANCE FOR WATER TANK .....	43
6.2.4 ELECTRICAL CHECKING .....	43
6.2.5 CHECKING FOR LASER PROTECTION DEVICE.....	43
6.2.6 REPAIR CYCLE .....	44
6.3 Fault analysis and troubleshooting method.....	44
6.3.1 WEAK LASER ENERGY.....	44
6.3.2 NO LIGHT IN OPERATION DURING NORMALITY IN TESTING.....	44
6.3.3 NO LIGHT BOTH IN OPERATION AND TESTING .....	44
6.3.4 MACHINE FAILS TO OPERATE IN ONE OR MULTIPLE DIRECTIONS.....	45
6.3.5 THE MACHINE IS NOT ENERGIZED.....	45
6.3.6 TRACKS OF MACHINE OPERATION HAVE OBVIOUS SAWTEETH.....	46
<b>Chapter 7 Technical Specification .....</b>	<b>47</b>

## 声明

版权所有 © 东莞市光博士激光科技股份有限公司保留一切权利。

未经东莞市光博士激光科技股份有限公司的许可,任何组织和个人不得擅自摘抄、复制本手册,并不得以任何形式传播。

## 商标声明



图形及文字均为东莞市光博士激光科技股份有限公司的注册商标,并对其享有独占使用、许可使用、转让、续展等各项法定权利,未经东莞市光博士激光科技股份有限公司允许,任何组织或个人不得在商品上使用相同或类似的商标。

## 注意

在所规定的支持保修范围内,东莞市光博士激光科技股份有限公司履行承诺的保修服务,超出规定保修范围的,恕不承担保修服务。对于在使用本产品过程中可能造成的损失,东莞市光博士激光科技股份有限公司不承担相关责任。如发生任何争议,应按中华人民共和国的相关法律解决。

东莞市光博士激光科技股份有限公司随时可能因为软件或硬件升级对使用说明书的内容进行更新,所有这些更新都将纳入使用说明书新的版本中,恕不另行通知。

## 前言

## 版本说明

本手册版本为 2016 中文简体 A 版,对应产品 GH/GN/D1210 系列激光切割机。本手册只适用于对应产品型号的标准配置,对于特殊定制的产品,请仔细阅读另附的说明资料。





本手册对产品的工作原理、安装方法、操作使用、故障排除、运输储存、维护保养等进行说明。如果你是第一次使用该产品,请在安装使用之前仔细阅读此资料。请妥善保管此资料,以便将来查阅参考。

## 符号说明

为了预防可能对人体造成的伤害或设备损坏,本手册用以下安全标志加以提示,

## 第 1 章 序言

在使用设备时请注意标志提示的内容，以确保您和周围人员的安全以及正确使用设备。

 <b>警告</b>
激光辐射注意内容，存在激光辐射的危险，请做好激光防护措施！
 <b>危险</b>
电气安全注意内容，可能引起触电的危险，造成人身伤害！
 <b>警告</b>
防火安全注意内容，可能引起火灾，注意防火！
 <b>注意</b>
一般注意事项，如不遵循该提示内容操作，可能造成设备的损坏和故障
 <b>说明</b>
对操作内容的描述进行补充和说明

### 1.1 欢迎

感谢您对光博士产品的青睐与厚爱，您购买的是东莞市光博士激光科技股份有限公司出品的 GH/GN/D1210 系列激光切割机。如果您是第一次使用该产品，请在安装使用前务必仔细阅读此使用说明书。

### 1.2 公司简介

光博士激光坚持“创造顾客，服务顾客，企业与员工共赢！”的核心价值，秉承“团结、拼搏、求实、创新”的企业精神；全力打造全球激光行业第一品牌。

公司愿景：让世界知道光博士，让光博士人自豪！

核心价值：创造顾客，服务顾客，企业与员工共赢！

品牌理念：致力激光应用智能化。

#### ● 产品

光博士激光 ----- 致力激光应用智能化，为国内外客户提供一整套激光加工解决方案及相关配套方案，主要产品包括：激光雕刻机 | 激光切割机 | 激光打标机 | 全自动送料打标机 | 全自动送料切割机等多个系列一百余种工业激光设备及其配套产品。广泛应用于电子电路、集成电路、仪器仪表、印制电路、计算机制造、手机通讯、汽车配件、精密器械、建筑建材、服装服饰、城市灯光、金银首饰、工艺礼品、印刷制版、标识、包装、广告、食品等行业。

#### ● 质量

光博士激光已通过 ISO9001: 2008 版国际质量体系认证，对产品的研发、采购、制造、检验等各个环节严格把关，确保出厂产品的性能和质量。

#### ● 服务

光博士激光拥有阵容强大的营销管理中心，在全国设立多家分公司、多家办事处，同时在海外设立多个分支机构，常驻技术服务与销售人員，为客户提供全面的售前、售中、售后支持和服务。力争做到有光博士激光产品的地方，就有光博士人的服务。

### 1.3 保修条款

一、整机保修一年（即从购买机器验收合格之日起计）：公司负责为客户保修机械及电子部分的时间为一年；易损件不保修（易损件指聚焦镜、反射镜等），国产激光管



保用六个月（因人为损坏不保），激光器保修壹年。

PS：因人为使用不当损坏的零件需收取人工、材料等费用（人为使用不当是指操作不当或保养、清洁不到位导致的故障问题而损坏的零件）。如下：

如有以下情形之一的，不属于保修范围：

- 1、X、Y 轴未加机油导致轨道磨损的；X、Y 轴轨道未清洗干净导致走不动或马达烧毁的；
- 2、镜片未清洗干净或螺丝松动发生光路偏位或激光功率降低影响切割效果的；
- 3、人为使网板损坏或不平导致切割效果不好的；
- 4、网板及漏斗式吸风箱未清理干净使排气效果降低产生切割布料发黄的；
- 5、吸风机未清理干净使之堵塞导致电机烧坏或不运作的；
- 6、冷却机因水量不足烧坏或水质污染导致水垢在冷却管内形成，造成冷却水堵塞，使激光器输出功率降低或炸裂的；
- 7、外力导致激光器破损或由于冷却效果不好而产生的玻璃管炸裂的。
- 8、激光管在离保修期限一个月内，如出现输出功率降低属正常功率损耗，客户需调到合适功率使用，不予免费更换。
- 9、不按正常程序操作导致加密狗软件丢失或插错端口导致光博士软件不能使用的；
- 10、图形本身原因或人为操作不当导致电脑软件无法运行的；
- 11、电脑（含显示器）硬件出现故障的；

二、在保修期外：客户需负责维修更换的零配件费用、公司技术人员的维修费用及往返交通费用。

## 第 2 章 安全说明和预防措施

鉴于机器所使用的是不可见高能量激光，请务必按照操作规范由经过培训合格的人进行机器的日常操作和维护，并请不要加工高温易爆材料，在机器加工运行期间必须有专人看管。在切割过程中可能含产生有毒气体物质时请注意开启抽风系统，否则禁止开机。

### 2.1 综述



注意

- a) 一定要确保此说明书保存在机器的最终使用者处。
- b) 机器的操作者和维护者须经我们公司人员或者是经我司授权的合格代理商进行培训后的合格人员。
- c) 确保使用者和维护者在机器的操作和维护过程中一定遵守相关要求，注意机器外部

和内部的相关标识。



警告

- d) 正确放置机器与其附件。
- e) 在给机器通电前，必须确保它已经良好接地。
- f) 设备在不工作时，请勿给其接通电源。
- g) 电源的保护地线要有良好的外部接地。
- h) 必须是对本设备的性能和操作都很熟悉的人员才能进行电气操作。
- i) 机器周围禁止堆放杂物。
- j) 抽风机请另外单独接地
- k) 工作时严禁将身体任何部位探入激光光路中，否则将会造成人身伤害。
- l) 不得把易燃材料放置到光路上或激光束有可能照到的地方。若激光束照射到易燃材料上，将会引起火灾甚至爆炸。
- m) 一定不能将激光电源输出端引线短路或接地
- n) 在激光器开机过程中，严禁用眼睛直视出射激光或反射激光，以防损伤眼睛。建议配戴激光防护眼镜

### 2.2 激光安全通告

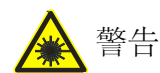

警告

由于 GN/GH/D1210 系列激光切割机采用部分封闭的激光光路设计，身体某部位进入切割区域的光路时会导致危险，因此要安全操作。要安全依照此说明书操作或者依照培训内容操作。

#### 2.2.1 眼和皮肤的保护



危险

请注意避免激光直射或者反射到眼和皮肤上，以免造成人身伤害，建议配戴防护眼镜。

#### 2.2.2 防火保护



警告

避免加工易燃易爆产品，不得把易燃材料放置到光路上或激光束有可能照到的地方。若激光束照射到易燃易爆材料上时，将会引起火灾甚至爆炸。

建议在机器附近放置一台合格的灭火器。

### 2.2.3 电气安全

请依照要求提供符合当地要求的电源，且一定要保证机器接地良好。

检修机器请一定在断开电源的情况下进行。

- a) 确保机器供电电源电压符合要求；
- b) 在给机器通电前，必须确保它已经良好接地；
- c) 设备在不工作时，请勿给其接通电源；
- d) 一定不能将激光电源输出端引线短路或接地；
- e) 电源的保护地线要有良好的外部接地；
- f) 必须是对本设备的性能和操作都很熟悉的人员才能进行电气操作；
- g) 本设备控制系统的测试，有些需采用一些特殊的测量技术。参考地的选择应有熟悉本系统操作和相关设备的技术人员决定；

### 2.2.4 材料安全通告

避免加工含硫，卤素等有毒元素的物品，在加工此类产品时请一定将抽风机打开，否则禁止开机工作。

### 2.2.5 机器的防护措施

本机器采取了一定的安全防护措施，具体如下：

- a) 电源短路 / 过载保护；
- b) 水流量信号保护；

### 2.2.6 使用人员常识

操作人员须完全依照此说明书操作或者依照培训内容操作。

- a) 不可在没有使用抽气及辅助吹气设备的情况下操作此设备；
- b) 操作时严禁将身体任何部位探入激光光路中，否则将会造成人身伤害；
- c) 严禁将身体任何部位探入运动的结构中，否则将会造成人身伤害；



注意

对容易引起着火的易燃材料，进行加工时，应准备一个随时可拿取的灭火器。

## 第 3 章 产品的概述

### 3.1 产品的主要型号

GN/GH/D1210 系列主要型号有：GN640、GN1080、GN1280、，GH1260T、GN1280T、GH750、GH960、GH1080、GH1260、GH1480、GH1690、GH1480T、GH1610T、GH1810T、D1210 等。

### 3.2 产品特点及外观图

GN/GH/D1210 系列机器具有长时间稳定可靠运行，操作简单，使用方便，标记清晰等特点。控制软件采用 Windows 工程界面，可兼容 Coreldraw, AutoCAD, Photoshop, Illustrator 等多种软件输出的文件。



图 3-1 GN 系列整机外形图



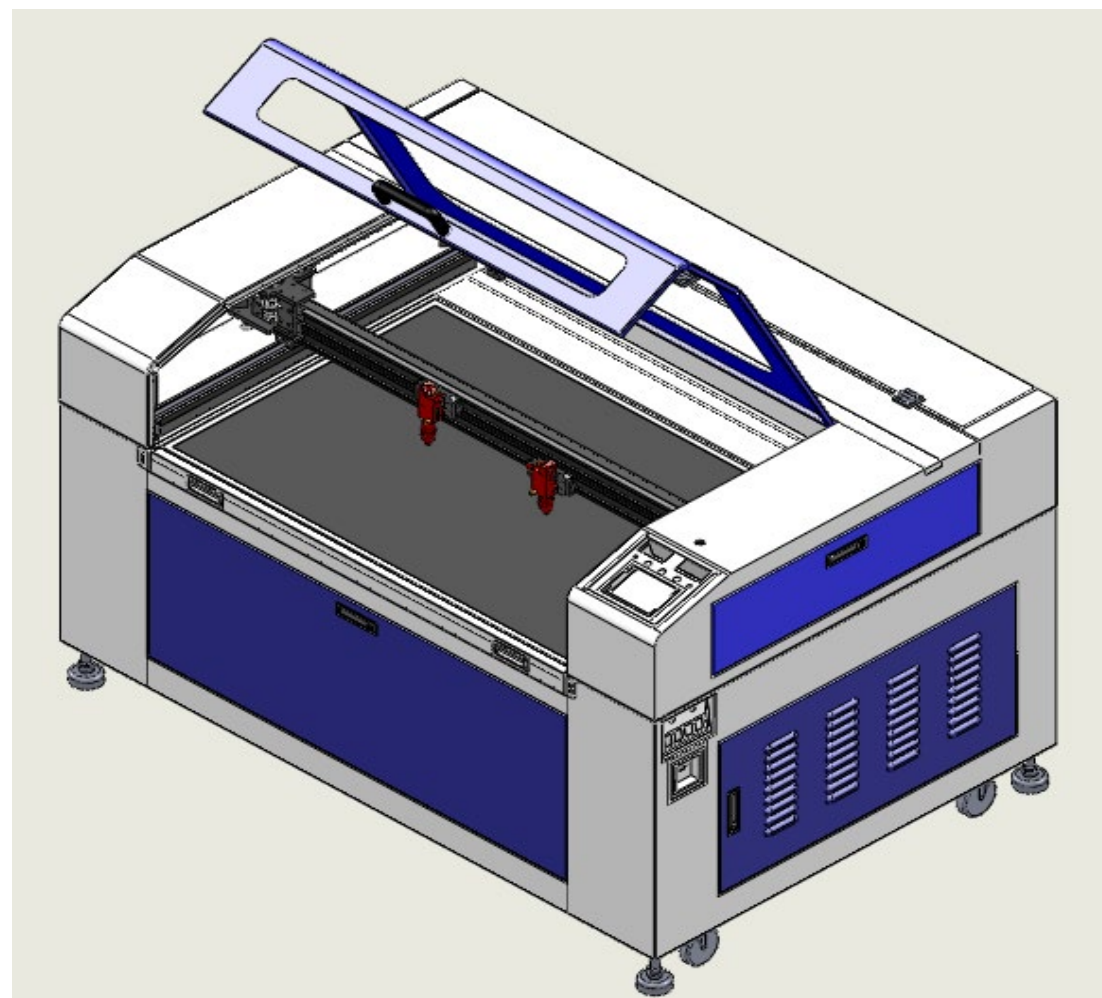

图 3-2 GH/D1210 系列整机外形图

### 3.3 型号定义说明

型号定义说明：

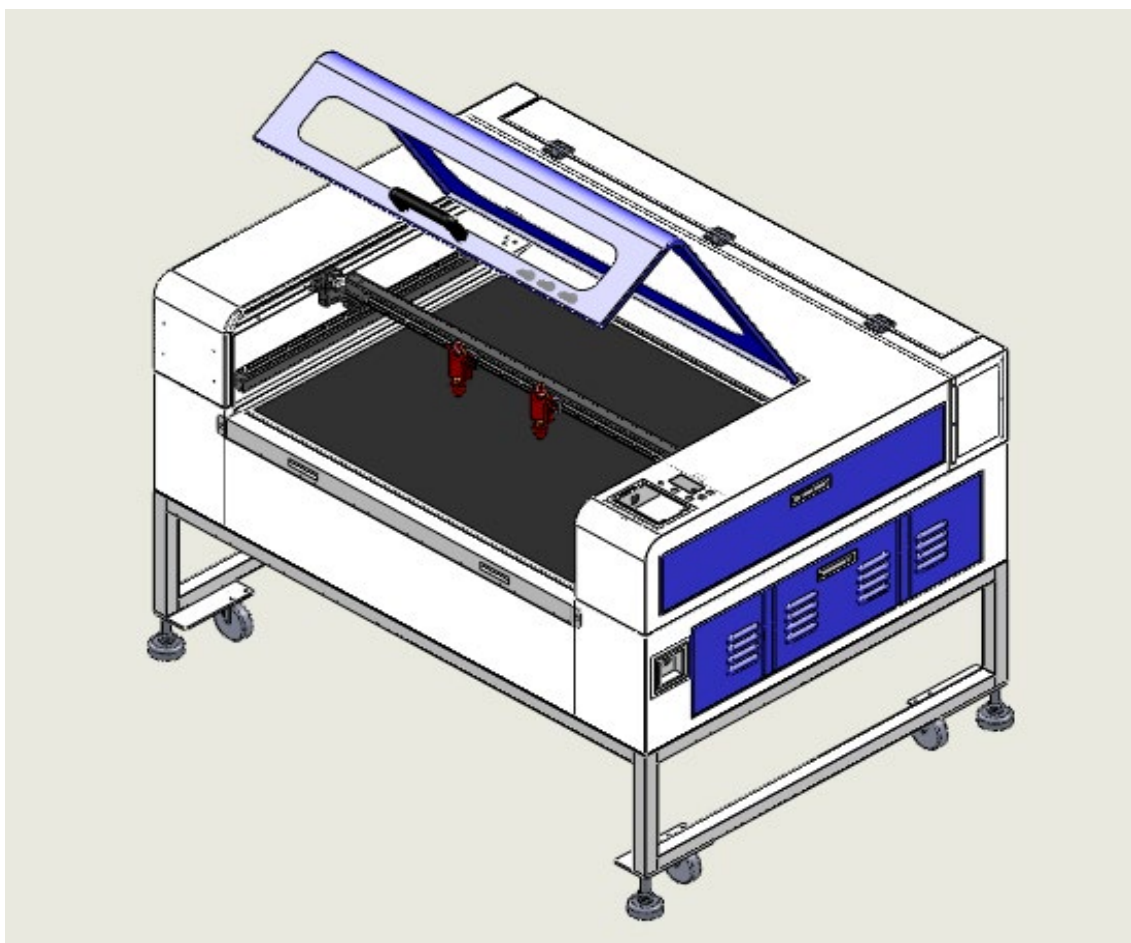

### 3.4 主要用途及适用范围

GN/GH/D1210 系列机型属于 CO<sub>2</sub> 非金属激光切割雕刻机，可加工多种非金属材料。如：木制品、纸张、布料、皮革、环氧树脂、亚克力、不饱和树脂、塑料等非金属材料。D1210 加辅助气体 O<sub>2</sub>，还可切割 1mm 以内的不锈钢和碳钢。

### 3.5 使用环境条件

该设备是按照有关工业环境规则设计的，东莞市光博士激光科技股份有限公司对因

安装在其他环境（住宅和家庭等环境）所引起的任何影响概不负责。

请在符合建议环境条件下使用，否则可能会对机器造成伤害或者对机器使用寿命造成影响。

建议使用环境：

使用环境温度	10℃ ~ 30℃
运输包装环境温度 e	5℃ ~ 45℃
相对湿度	30% - 80%
电力需求	单相 220VAC, 50HZ/60HZ, 10A-20A
电网波动	< ±5%
电网地线	符合机房国标要求

另外请避免安装在以下的场所使用：

- 垃圾、灰尘、油雾较多的场所；
- 震动以及冲击多的场所；
- 能触及药品和易燃易爆物的场所；
- 高频干扰源附近的场所；
- 易结露的场所；
- 在 CO<sub>2</sub>、NO<sub>x</sub>、SO<sub>x</sub> 等浓度高的环境中。

### 3.6 对环境及能源的影响

本设备使用的是 CO<sub>2</sub> 激光源，属于接触 / 非接触式加工，在加工进行过程中会有一些的噪音、化学（受加工材料限制）、烟尘、空气的污染。

### 3.7 工作原理

GN/GH/D1210 系列激光设备由控制系统、光学系统、XY 运动系统、工作台、水冷系统等组成。CO<sub>2</sub> 激光器输出波长为 10.55 μm 到 10.63 μm 的激光，由反射镜折射后，通过聚焦镜聚焦，经过激光嘴，形成一个个细微的、高能量密度的光斑击穿工件表面，在工件表面形成一个细微的小孔，通过控制 XY 运动可使这些小孔排列成相应的形状，从而达到物体切割的目的。

#### 3.7.1 控制系统（另见控制系统操作指南）

#### 3.7.2 主机模块



图 3-3 GN 系列



图 3-4 GH /D1210 系列

### 3.7.3 光学系统

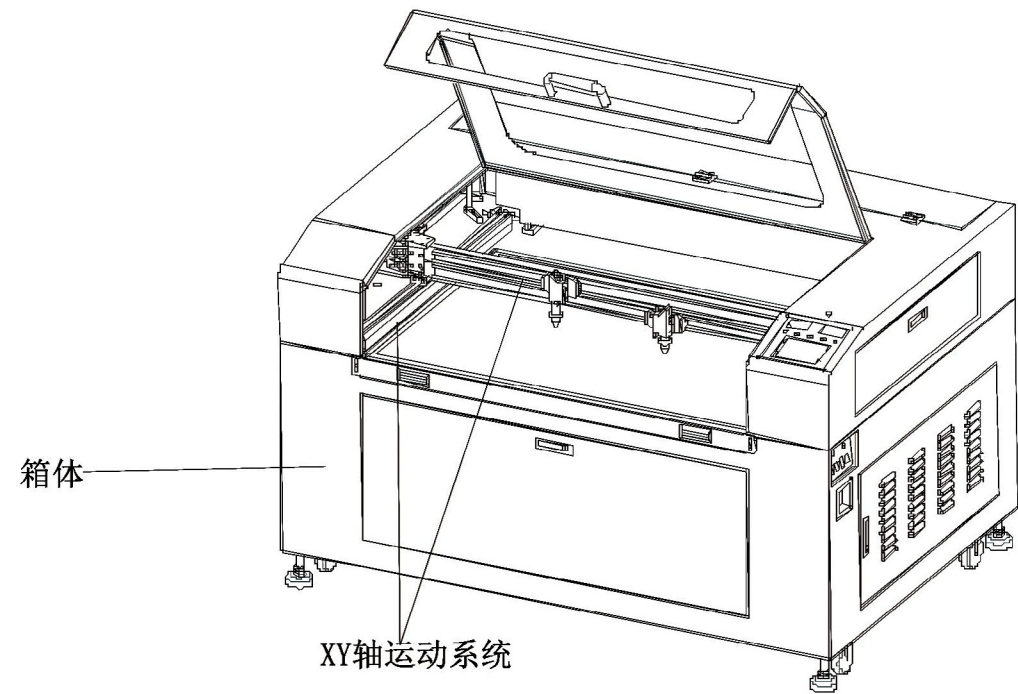

图 3-5 光路原理

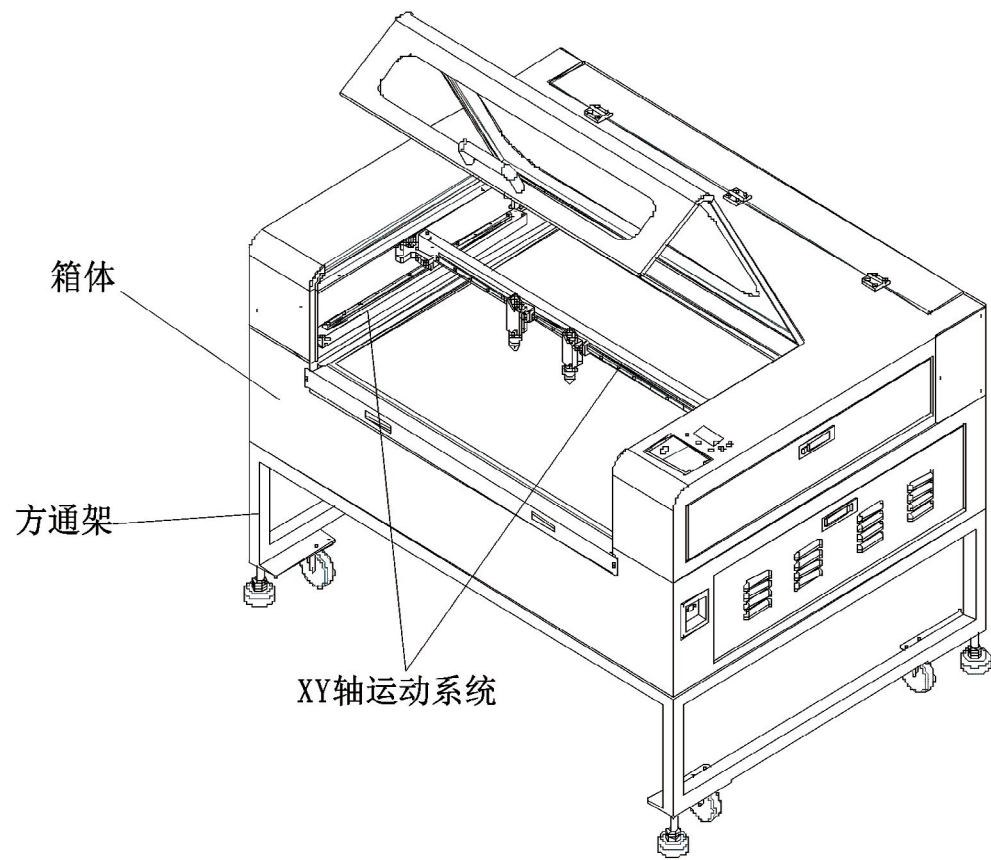
### 3.7.4 工作台

标准配置蜂窝网板工作台，可选配刀条状工作台。

### 3.7.5 排风系统

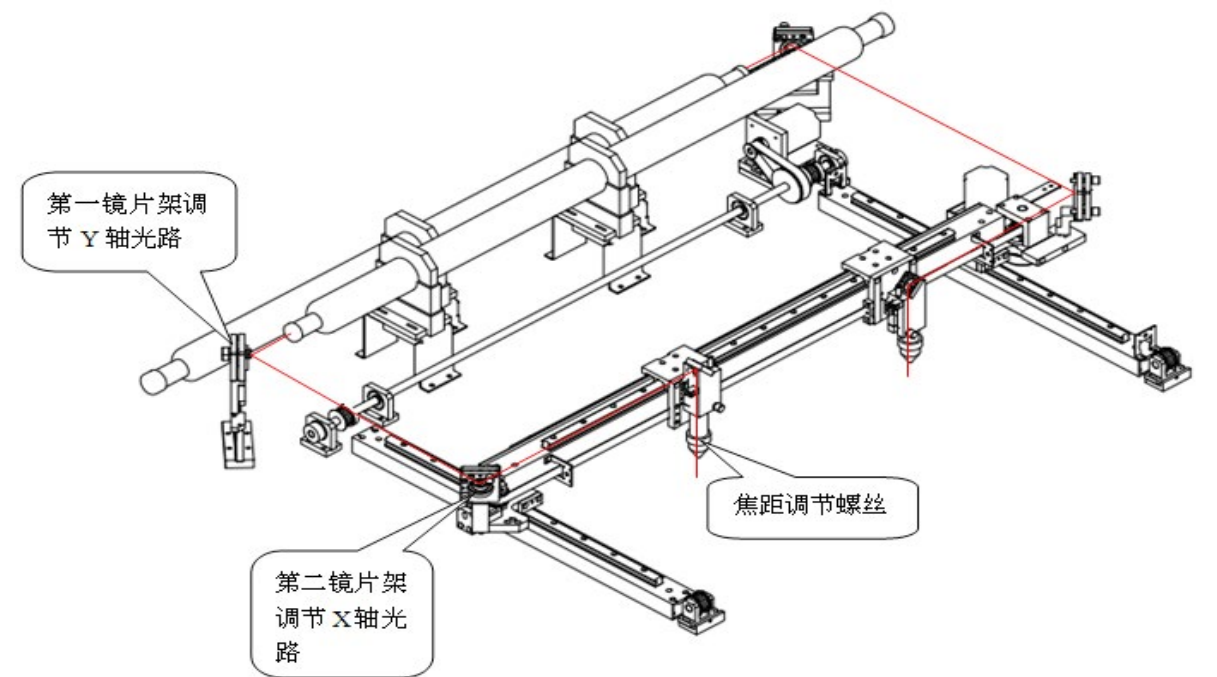
主要部件为风机，如下图：



图 3-6 风机

在激光加工过程中，被加工材料表面会产生大量的烟尘或有害气体，必须利用风机及风管将烟尘或有害气体排出室外。

### 3.7.6 冷却系统: (如下图)

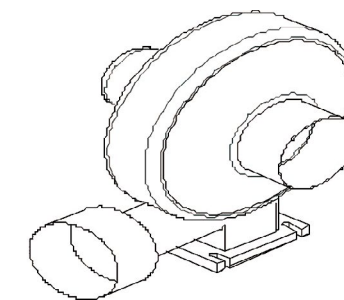

冷却水箱采用不锈钢多级离心式特种循环泵、PVC 连接管路，无生锈或腐蚀产生，可直接使用纯净水，配置耐高压纯水过滤装置，确保管路无脏堵，使激光设备运行更安全。



图 3-7 水箱

## 第 4 章 安装、调试

### 4.1 交货检查

我们尽力为客户着想，但可能由于各种原因造成客户收到机器时有些不尽如人意的地方，请客户收到机器后依据装箱单进行逐项检查，确认机器各部分与附件在装箱与运输过程中没有缺失和损坏，如有，请及时与我司（含我司授权代理）联系，以便我们尽快处理。

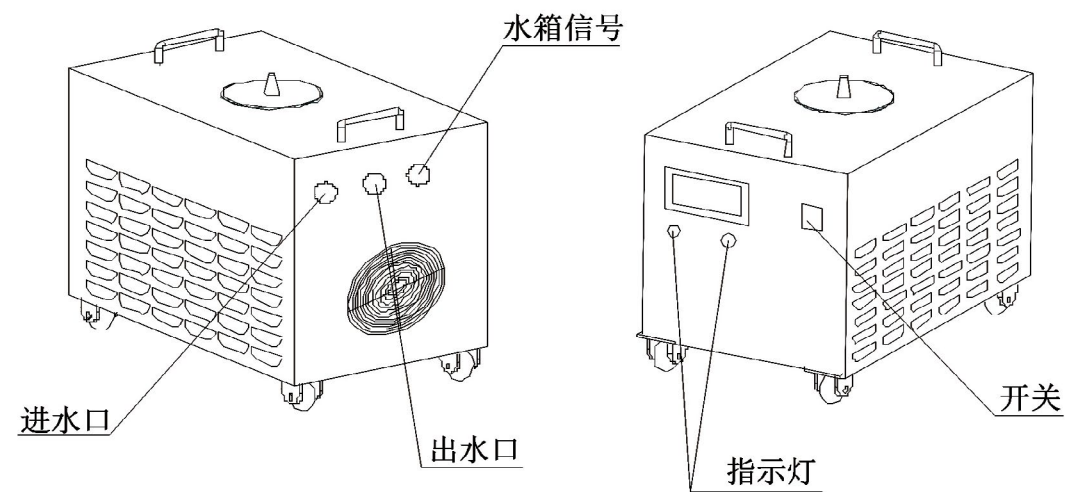
#### 4.1.1 开箱注意事项

请客户收到机器后依据装箱单进行逐项检查，确认机器各部分与附件在装箱与运输过程中没有缺失和损坏，如有，请及时与我司（含我司授权代理）联系，以便我们尽快处理，谢谢！

如果装箱单器件没有缺失并状态良好，请准确填写保修单并尽快传真给我司或者我们的授权代理商，以便我们建立客户档案，为我们以后的服务和更进一步工作准备。

#### 4.1.2 检查内容

具体请依据装箱单，仔细检查确认机器各部分与附件外观，性能是否良好

### 4.2 安装环境要求

请在周围无急剧温度变化的场所使用。另外请避免安装在以下的场所使用：

- 垃圾、灰尘、油雾多的场所；
- 震动以及冲击多的场所；
- 能触及药品和易燃易爆物的场所；
- 高频干扰源附近的场所；
- 易结露的场所；
- 在  $\text{CO}_2$ 、 $\text{NO}_x$ 、 $\text{SO}_x$  等浓度高的环境中。

在温度急剧变化的场合，光学镜头上会结露，出现污迹和雾斑，务必防止急剧的环境温度变化，若难以避免，则请在确保无结露后使用该设备。

请将机器安装在水平无外界震动的环境条件下，且确保有一定的工作空间。为方便起见，请将机器安装在有压缩空气且易排风排烟的位置。

### 4.3 安装方法及注意事项

#### 4.3.1 校水平

将机器放置于平整的地面，找到合适的安装位置，锁紧脚轮，使脚轮不再转动，升起脚杯。注意各脚杯要全部接触安装平面，通过 4 个脚杯调整机器的水平，并用水平仪检测。



图 4-1 校水平

#### 4.3.2 水箱连接

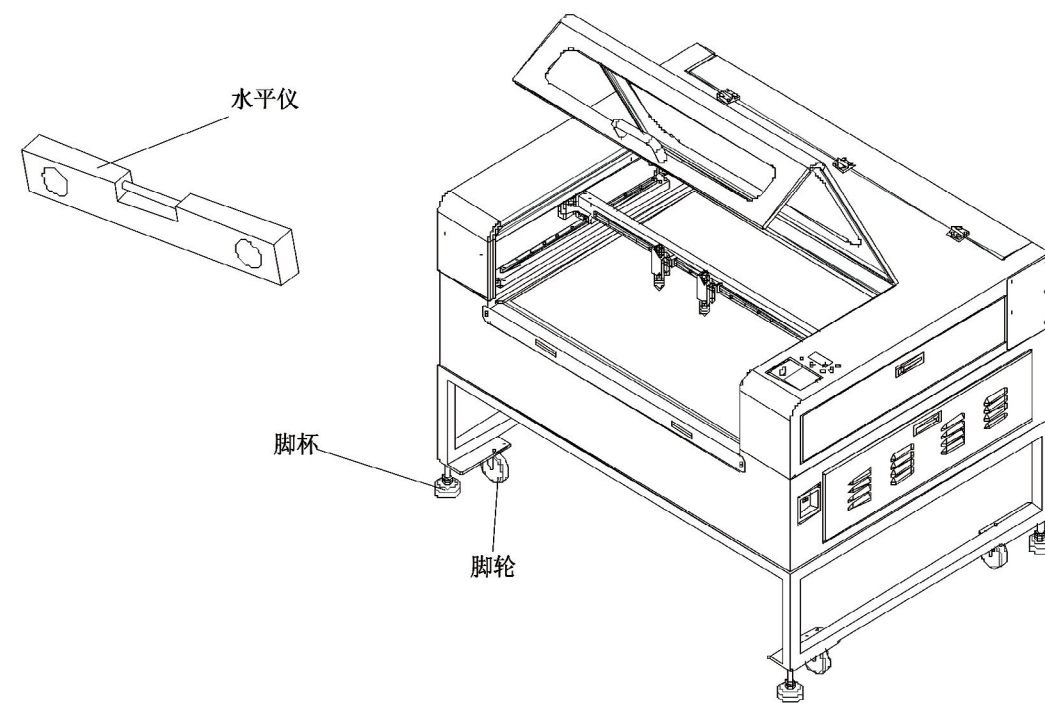

图 4-2 水箱连接

### 4.3.3 风机 / 电源线连接

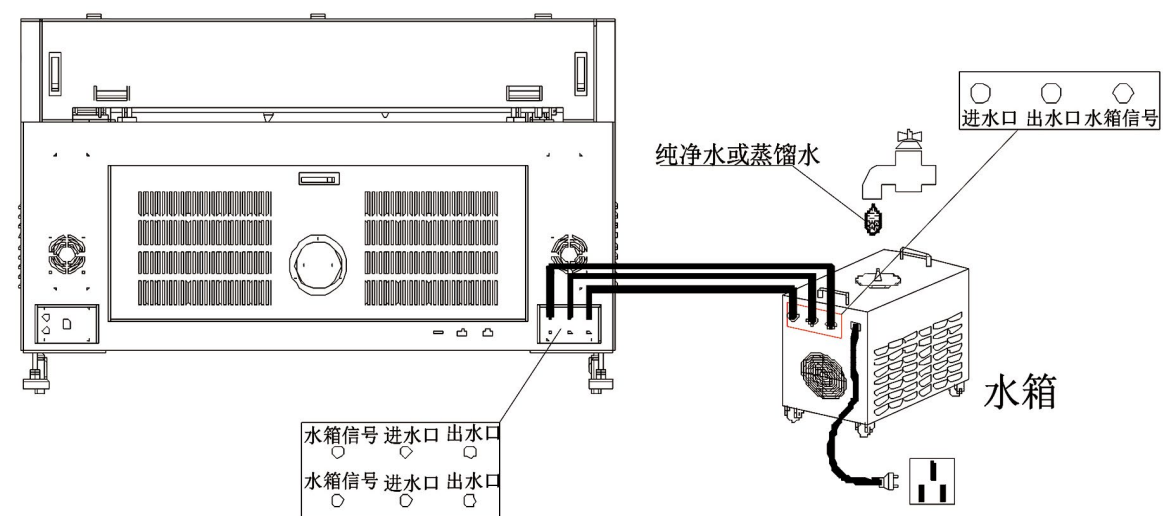

图 4-3 风机 / 电源线连接

## 4.4 调试方法及注意事项

将一张白纸平放在工作台上，然后根据其到激光嘴的距离粗步调整高度，之后按下

操作面板上的测试按钮，激光会在材料上打下一个痕迹，然后手动调节振镜头高度，再次按下按钮开关，再次在材料上打下一个痕迹，比较两者的痕迹大小，重复上述的调节切割头高度和打点步骤，直到痕迹最小，则此时为焦点位置。

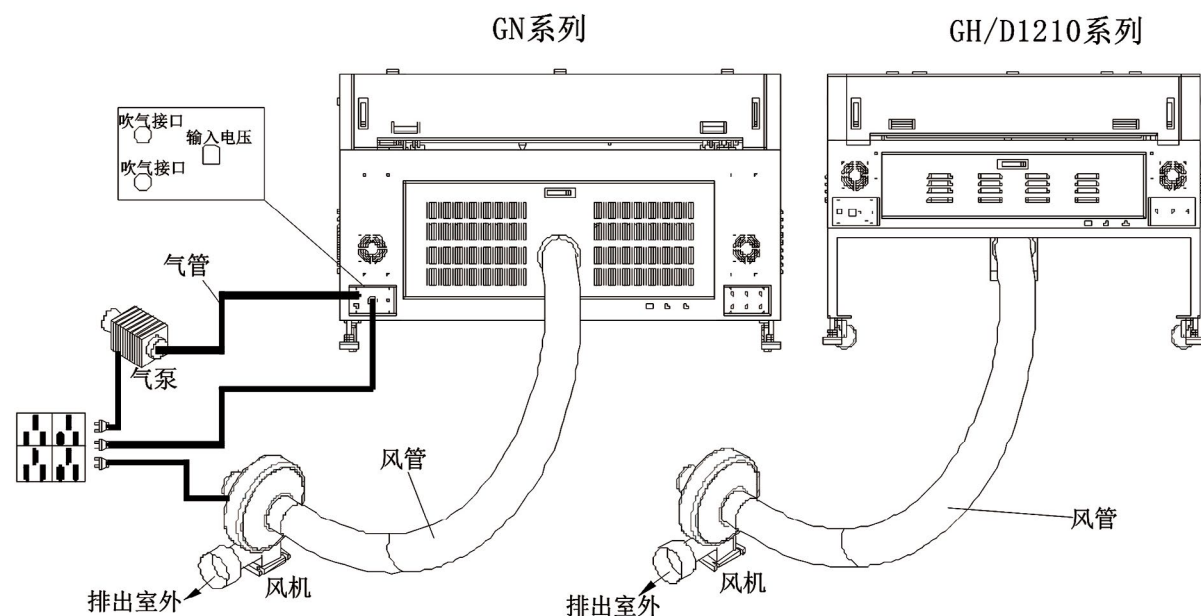
工具：公制内六角扳手一套



注意

调试之前必须检查，辅助气体，聚焦镜片等是否正常。

测试按钮开关用于触发激光，不可长时间按下按钮

## 第 5 章 使用须知

### 5.1 使用前的准备和检查

- 1、水冷系统：用户自行将水箱加满纯净水（推荐用蒸馏水）检查水箱及连接水管无漏水。
- 2、电源：确认是否接入 220V 工业电源，接口是否松动。
- 3、气源：将气泵 / 压缩空气的气管接入机器。
- 4、排风系统：确认风机 \ 风管是否连接正确，保证烟尘能够排到室外确认无误后，方可开机调试。

### 5.2 整机开机程序

- 1、确保安全接通设备电源；
- 2、开总电源
- 3、开水箱电源
- 4、开气泵和风机
- 5、点击开机按钮

### 5.3 整机关机程序

- 1、点击关机按钮
- 2、关闭气泵和风机
- 3、关闭水箱电源
- 4、关闭总电源



图 5-1 开关机程序

## 第 6 章 维护、保养和故障排除

为确保和延长机器的使用寿命，一定的日常和定期维护保养检查是不可缺少的，请依据具体情况制定日常维护保养计划。

### 6.1 综述

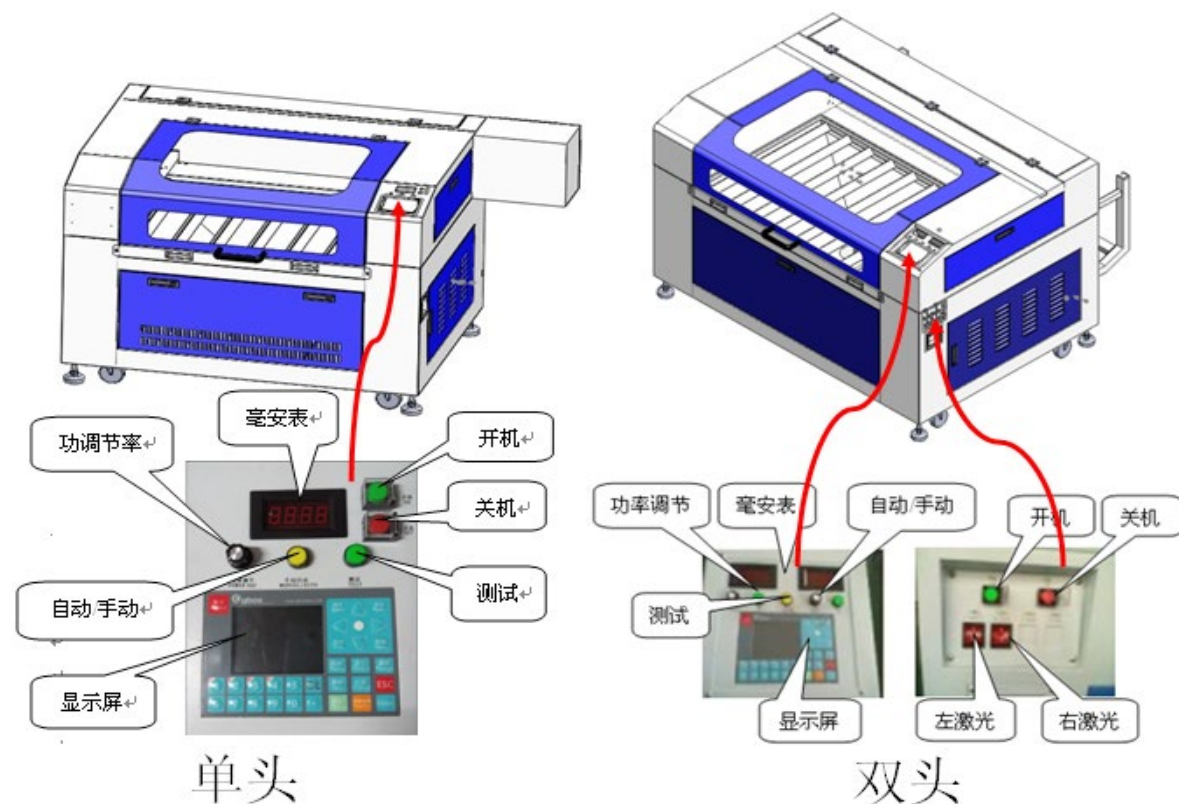
维护保养主要指机器的外观保养，抽风机，光学系统，冷却系统，激光保护装置，电器系统等定期和不定期检查维护和保养。

### 6.2 日常维护、保养

每班工作完之后，首先清洁机器周围的环境，使地面无尘、洁净。然后做好设备的清洁，包括主控柜的外表面、光学系统罩壳、工作台面等要无杂物、无尘、洁净。

#### 6.2.1 风机检查和维护

每次开机前，请清理机器抽风口、风机及风管内部的杂物（每周清理一次），检查抽风机的风管有无折住，保证风机排风效果良好。

#### 6.2.2 光学系统检查和清洁

光学镜片存放及安装时应注意使镜片免于受损和污染。使用中的镜片应定期（每周

定期检查必要时须清洗)的进行清洁。未定期进行清洁保养的镜片则会降低使用寿命。

在激光工作时，当激光对材料进行切割、焊接、热处理时，工件表面会释放大量的气体和飞溅物，这些气体和飞溅物将会对镜片造成伤害。当污染物落在镜片表面，将会从激光束吸收能量，导致热透镜效应而损伤镜片。应时刻检查镜片是否被污染，做到及时清洁。

正确的清洗方法

清洗镜片的过程中，唯一的目的是将镜片的污染物去除，并且不要对镜片造成进一步的污染和损坏。

第一步：用空气球将表面的浮物及微小颗粒吹掉。



注意

不能使用压缩空气，因为这些空气中含有油物和水滴，会加深对镜片的污染。

第二步：应用无水乙醇对镜片作轻微清洗。使用棉签或擦镜纸蘸上无水乙醇在光照下清洗镜片，并做环状移动。

如果无水乙醇不能将所有的污物去除，请使用酸醋清洗。酸醋清洗是利用酸对污染物的溶解来达到清除污物的，不会对光学镜片造成伤害。这种酸醋可以是实验级别的（稀释到 50% 强度），或者家庭用的 6% 乙酸的白醋亦可。清洗的程序与无水乙醇清洗一样，然后再用无水乙醇来去除酸醋和擦干镜片。



注意

如果污染物和镜片损伤无法通过清洗去除，特别是因金属飞溅和污垢引起的膜层烧坏，要想恢复良好的性能，唯一的办法就是更换镜片。

### 6.2.3 水箱的检查和维护

开机前检查：

- 1、电源插座接触是否良好，工作电压是否稳定、正常
- 2、检查水箱水位：查看水箱中的水是否充足
- 3、进 / 出水口连接是否正常，有无松动、漏水现象，水流是否畅通，有无堵塞
- 4、检查水温设定是否过高，正常为 20-30℃

维护及保养：

- 1、定期换水（使用纯净水或蒸馏水）
- 2、每天清理入风口 / 出风口的过滤网





注意

- 1、严禁无水运行，机器工作前一定要保证激光管内充满循环水
- 2、水箱散热时在达到一定的温度风扇才会转动
- 3、确保水箱入风、出风通道顺畅（水箱后面的出风口 / 入风口距离障碍物要留有 30CM 以上的距离）
- 4、当水温低于环境温度，产生冷凝水的情况时，建议调高水温设定或将水温加高到 10℃ 左右。

#### 6.2.4 电气检查

请定期清洁电控制柜中的灰尘，检查线路有无松动、脱落、鼠啮等，检查各排风扇的工作情况。

#### 6.2.5 激光保护装置的检查

请定期检查机器的激光使能开关，气压保护开关，流量保护开关是否正常。

#### 6.2.6 检修周期

请依照实际情况制订检修计划进行相应检修。

### 6.3 故障分析及排除方法

#### 6.3.1 激光能量弱；

原因：

- a、光路偏移；
- b、镜片上有污物；
- c、镜片有损伤；
- d、激光器老化。

检查方法：

- a、查看各个镜片的入射光是否在镜片的中心位置
- b、镜片（聚焦镜、反射镜、合束镜）是否洁净；
- c、镜片（聚焦镜、反射镜、合束镜）是否损伤；
- d、直接在激光器的激光出口测试激光的功率。

处理方法：

- a、调整光路（方法参见 4.5 调整方法）；
- b、用棉签或擦镜纸、无水乙醇擦拭镜片（方法参见 7.2.2 光学系统检查和清洁）；
- c、更换损坏镜片；
- d、更换激光器。

#### 6.3.2 运行不出光，测试出光正常；

原因：

加工参数不正确。

检查方法：

检查加工功率设置。

处理方法：

重新设置加工参数。

#### 6.3.3 机器无论测试或加工均不出光

原因：

- a、光路偏移；
- b、激光开关没有打开；
- c、激光开关损坏或连线接触不良；
- d、激光器或激光电源损坏。

检查方法：

- a、查看各个镜片的入射光是否在镜片的中心位置
- b、检查激光使能开关：使能指示灯
- c、检查控制卡的输入信号、输出信号、激光器连接的连接线是否正常，激光电源与激光器连接是否正常；
- d、激光电源的指示灯是否点亮

处理方法

- a、调整光路
- b、打开激光使能开关；
- c、重新连接好连线；
- d、更换激光电源的保险，更换激光电源。

#### 6.3.4 机器一个或多个方向不能动作；

原因：

- a、伺服电机报警；
- b、限位开关连接线接触不良；
- c、限位开关被污物遮挡或损坏；
- d、控制卡、驱动器、电机线路故障；

检查方法：

- a、检查相应的报警代号
- b、检查相应限位开关与控制卡之间的连接线；
- c、检查限位开关是否有污物遮挡或限位开关被遮挡与无遮挡时是否有相应的变化；
- d、检查控制卡、电机、驱动器的连线；

处理方法:

- 对相应代号故障针对性处理
- 重新连接限位开关与控制卡的连接线;
- 清理污物或更换限位开关;
- 重新连接控制卡、电机、驱动器的连线;

### 6.3.5 机器不通电

原因:

- 电源线接触不良;
- 急停开关被锁定;
- 启动按钮与接触器之间的连接线故障;
- 启动按钮或接触器故障。

检查方法:

- 检查电源供电情况和电源连接线;
- 检查急停开关的状态;
- 检查启动按钮与接触器之间的连接线故障;
- 检查启动按钮与接触器。

处理方法;

- 重新连接电源线;
- 打开急停开关;
- 重新连接启动按钮与接触器之间的连接线故障;
- 更换启动按钮与接触器。

### 6.3.6 机器运行时轨迹有明显锯齿

原因:

- 运行速度、加速度设置设置过大;
- 驱动器与电机线连接故障;
- 电机损坏;
- 运动部分有固定螺丝松动;

检查方法:

- 检查运动速度, 加速度设置 (切割速度 $\leq 9000\text{mm}/\text{min}$ , 加速度级别增大);
- 检查驱动器与电机线连接;
- 检查电机;
- 检查运动部分的螺丝是否固定;

处理方法:

- 重新设置运动速度, 加速度;
- 重新连接驱动器与电机线连接;
- 更换电机;
- 固定各个导轨上的螺丝;

查找 / 排除线路故障时请一定断电作业, 在机器故障排除以前请不要作业。

## 第 7 章 技术规范

本章列出了产品的主要功能规格和参数等

### 一、GN/GH/D1210 激光设备的技术参数具体如下:

型号	GN/GH/D1210
激光器类型	国产激光管 (玻璃)
冷却方式	水冷
加工方式	平面
激光功率	70W-180W 可选
激光波长	10.6um
最小线宽	0.15mm
加工线速	$\leq 300\text{mm}/\text{s}$
重复定位精确度	$\pm 0.05\text{mm}$
雕刻深度	$\leq 5\text{mm}$
最小字符	1mm

以上参数适用于 GN/GH/D1210 系列机型

### 二、GN/GH/D1210 系列机型基本参数

型号	加工范围 (mm)	外形尺寸 (mm)	重量 (Kg)	供电电源
GN640	600*400	1120*760*970	170	220V 50Hz/60Hz 10Amax
GN1080	1000*800	1450*1090*970	220	220V 50Hz/60Hz 10Amax
GN1280T	1200*800	1850*1250*1000	300	220V 50Hz/60Hz 10Amax
D1210	1200*1000	1900*1530*1027	220	220V 50Hz/60Hz 10Amax
GH750	700*500	1250*900*970	160	220V 50Hz/60Hz 10Amax
GH960	900*600	1460*1000*970	190	220V 50Hz/60Hz 10Amax
GH1080	1000*800	1560*1150*982	220	220V 50Hz/60Hz 10Amax
GH1260T	1200*600	1790*1150*1006	280	220V 50Hz/60Hz 10Amax
GH1280T	1200*800	1900*1420*1006	300	220V 50Hz/60Hz 10Amax
GH1480T	1400*800	2100*1300*1006	325	220V 50Hz/60Hz 10Amax
GH1610T	1600*1000	2300*1530*1007	380	220V 50Hz/60Hz 10Amax
GH1810T	1800*1000	2420*1530*1006	400	220V 50Hz/60Hz 10Amax

以上参数仅供参考, 光博士激光有最终解释权

## Statement

All rights reserved © Gbos Laser Inc.

This Manual cannot be extracted, copied and distributed in any form by any organizations and individuals without prior permission of Gbos Laser Inc. (hereafter referred to as “the Company”).

### Trademark statement

Both graphics and texts in  are registered trademarks of Gbos Laser Inc., which owns the legal rights of exclusive use, licensed use, transfer and renewal of trademark above. No organization or individual shall use the same or similar trademarks on commodities without prior permission of the Company.

### Attention

The Company is liable for maintenance of products within warranty scope only, and shall not bear any liabilities for any losses during usage of this product. Disputes (if any) shall be settled according to laws of the People’s Republic of China.

The Company will not send prior notice regarding update of instruction manual due to software or hardware upgrading. All such updates will be added in new versions of the instruction manual.

## Preface

### Version introduction

This Manual is 2016 English A version which is focused on the introduction of GN/GH/D1210 Laser Cutting and Engraving Machine. Please refer to attached data for other special products since this Manual is applicable to the standard configuration of corresponding products only.

The working principle, installation method, operations, troubleshooting, transport and storage and maintenance of the product are introduced in this Manual. Please read the relevant information carefully prior to installation and usage.

Please keep the Manual in a secure place for further reference.

### Symbol introduction

The safety symbols below are used in the Manual to prevent injury to people and damage to equipment. Please pay attention to the safety symbols to ensure personal safety and proper usage of equipment.

 <b>Warning</b>
Danger of laser radiation. Please take protective measures!

 <b>Danger</b>
Danger of electric shock which may cause personal injury!

 <b>Warning</b>
Risk of fire. Pay attention to fire protection!

 <b>Attention</b>
General precautions, equipment damages and faults may occur if violated.

 <b>Instruction</b>
Supplemental instruction of operation details.

## Chapter 1 Preface

### 1.1 Welcome

Thanks for choosing Gbos products. The product you purchased is GN/GH/D1210 Laser Cutting and Engraving Machine from Gbos Laser Inc..

If using the product for the very first time, please carefully read this Manual before installation and usage.

### 1.2 Company profile

By insisting on the core value of “create customer, serve customer ,Companies and employees win-win” and the enterprise spirit of “being united, diligent, practical-minded and innovative”, we try to become the first brand in laser industry worldwide.

Company vision: All GBOS people will be proud of the well-known GBOS.

Core value: create customer, serve customer, Companies and employees win-win.

Brand concept: dedicated to smart laser application.

#### ● Product

GBOS laser- is dedicated to laser application automation by providing clients both at home and abroad with one whole set of laser processing solution and relevant supporting schemes; the main products include several series of industrial laser equipment and supporting products in more than 100 kinds, such as laser engraving machine | laser cutting machine | laser marking machine | full automatic marking machine. Our products have been widely used in such industries as electronic circuit, integrated circuit, instrument, printed circuit, computer manufacturing, mobile communications, auto accessories, precise machinery, construction and building materials, costume, city lights, gold & silver jewellery, craft gift, printing platemaking, mark, packaging, ads and food.

#### ● Quality

Gbos laser has passed ISO9001 2008 internal quality system certification and is strictly controlled in terms of R&D, purchase, manufacturing and inspection in order to guarantee the performance and quality of products.

#### ● Service

Gbos laser has a powerful marketing management center and multiple offices and branches as well as technical, service and sales personnel at home and abroad to provide pre-sales and after-sales service for customers. The company works to make Gbos service accessible to all customers.

### 1.3 Warranty Terms

#### 1. Period of warranty

This machine is warranted for one year since the date of delivery (subject to the date as stated in the nameplate), except for the following parts: CO2 glass laser tube guarantee 6 months, No guarantee

for the optical lens and mirror, and other consuming parts.

#### 2. Warranted items

- a. Maintainable parts sold by Gbos Laser Inc..
- b. We provide free maintenance service and technical supports for the fault caused by non-human factors during the period of warranty; both round turn freight cost(replacement parts and return broken repairable parts) and traveling expenses shall be borne by the user. Before maintenance, please show warranty card or invoice to our technicians.
- c. For online after-sales service, the user shall provide the equipment series number with fault descriptions to our technicians, and then we will provide connection service or send reply via e-mail within specific time.

#### 3. We are not responsible for free maintenance in any of the circumstances and the user has to pay the relevant fees based on the actual situations.

- a. Problems not caused by product quality;
- b. The period of warranty has expired;
- c. The user is unable to show warranty card or warranty card is modified or damaged;
- d. The user fails to perform relevant responsibilities as stated in the contract/invoice;
- e. The user assembles, maintains the machine or changes machine configuration arbitrarily without our permission and the guidance of our professional staffs;
- f. Problems caused by relevant people or force majeure;
- g. The rail is worn as the user fails to add engine oil according to the requirements or the motor is burn by the failure in regularly cleaning it based as required;
- h. The suction fan is not cleaned thoroughly and thus blocked, burning the motor or making the motor unable to operate;
- i. The cooler is burnt due to insufficient water or water pollution makes scale form within the cooling tube, resulting in the blockage of cooling water, reducing output power of laser or exploding the laser;
- j. Fault happens to laser as the operating environment dissatisfies the requirements;
- k. Laser is damaged due to external force or the glass tube is exploded by the poor cooling effect;
- l. If he output power of the laser tube is reduced within one month before the expiration of period of warranty, it actually belongs to the normal power consumption and we will not change it freely if the user uses it by adjusting to the proper power;
- m. Failure in operating according to the normal program will result in the loss of softdog software or the failure in inserting the port correctly will make Gbos software inapplicable;
- n. The computer software can not be operated by the graph or artificial operation;
- o. Fault happens to computer hardware (including display).

#### 4. We hold legal liabilities for this machine in lieu of any indirect loss.

#### 5. We hold legal liabilities for the products sold in lieu of any liabilities caused by using our products.

## Chapter 2 Safety Instruction and Preventive Measures

The machine shall be operated and maintained by trained personnel according to operation specification since the machine uses invisible high-energy laser. A specially-assigned person shall be liable for the operation management. High-temperature and explosive materials shall not be processed.

The machine cannot be operated before starting the air suction system since poisonous gas and materials may be generated during cutting.

## 2.1 Review



Attention

- a) This Manual must be kept by the end user of the machine.
- b) The operator and maintainer must pass training by the authorized and qualified agent of our Company.
- c) The operator and maintainer shall comply with related requirements during operation and maintenance and pay attention to external and internal symbols.



Warning

- d) Place the machine and accessories properly.
- e) Make sure the machine is well grounded before power supply is connected.
- f) Make sure the power supply is disconnected when the machine is not in use.
- g) The protective ground wire of power supply shall be securely grounded.
- h) The machine's electrical operation shall be implemented by personnel who are familiar with performance and operation.
- i) The machine shall be away from sundries.
- j) The suction fan shall be separately grounded
- k) Do not put any part of body in the optical path of laser during work to avoid personal injury.
- l) Do not place flammable materials in optical path or the reachable area of laser beam, otherwise, fire or even explosion may occur.
- m) The laser power output lead must not be subject to short circuit or grounding
- n) To avoid hurting your eyes, do not look directly at the outgoing laser or reflected laser during startup of laser device. Operators should wear protective eyeglasses.

## 2.2 Laser safety notice



Warning

The GN/GH/D1210 series laser cutting machine shall be safely operated by following instruction manual or training content since it is provided with partially enclosed laser optical path and it is dangerous if any part of body enters the optical path of cutting area.

### 2.2.1 Protection of eyes and skin



Danger

Direct or indirect contact between laser and eyes and skins shall be avoided and protective glasses shall be worn to avoid personal injury.

### 2.2.2 Fire protection



Warning

Do not process flammable and explosive products or place flammable materials on optical path or the reachable area of laser beam

A qualified fire extinguisher shall be placed near the machine.

### 2.2.3 Electrical safety

Please provide power supply which meets local requirements and guarantee the good grounding of machine.

The machine shall be inspected and maintained when power supply is disconnected.

- a) Make sure that power supply voltage meets requirements.
- b) Make sure the machine is well grounded before power supply is connected.
- c) Make sure the power supply is disconnected when the machine stops working.
- d) The laser power output lead must not be subject to short circuit or grounding.
- e) The power supply protective ground wire shall be securely grounded.
- f) The machine's electrical operation shall be implemented by personnel who are familiar with performance and operation.
- g) Special measuring techniques are required to test the machine's control system. Reference ground shall be selected by personnel who are familiar with performance and operation.

### 2.2.4 Safety notice of material

Articles containing toxic elements such as sulfur and halogen shall not be processed. The suction fan must be started if such articles are processed, otherwise, the machine shall not be started.

### 2.2.5 Protective measures of equipment

This machine is provided with safety protective measures as follows:

- a) Short circuit/overload protection of power supply;
- b) Protection of water flow signal;

### 2.2.6 General knowledge for user

The operators must operate the machine according to this instruction manual and training content.

- a) Do not operate this machine without air suction and auxiliary ventilation equipment.



- b) Do not put any part of body in the optical path of laser during operation to avoid personal injury.
- c) Do not put any part of body into the moving structures to avoid personal injury.



Portable fire extinguishers shall be provided and available when processing flammable materials.

## Chapter 3 Product Overview

### 3.1 Main models of product

GN/GH/D1210 series machine mainly includes GN640, GN1080, GN1280, GH1260T, GN1280T, GH750, GH960, GH1080, GH1260, GH1480, GH1690, GH1480T, GH1610T, GH1810T and D1210.

### 3.2 Product characteristics and external view

With the characteristics of long-time stable operation, simple operation and use and clear marking, the GN/GH/D1210 series machine uses Windows engineering interface and is compatible with the output files of Coreldraw, AutoCAD, Photoshop and Illustrator.

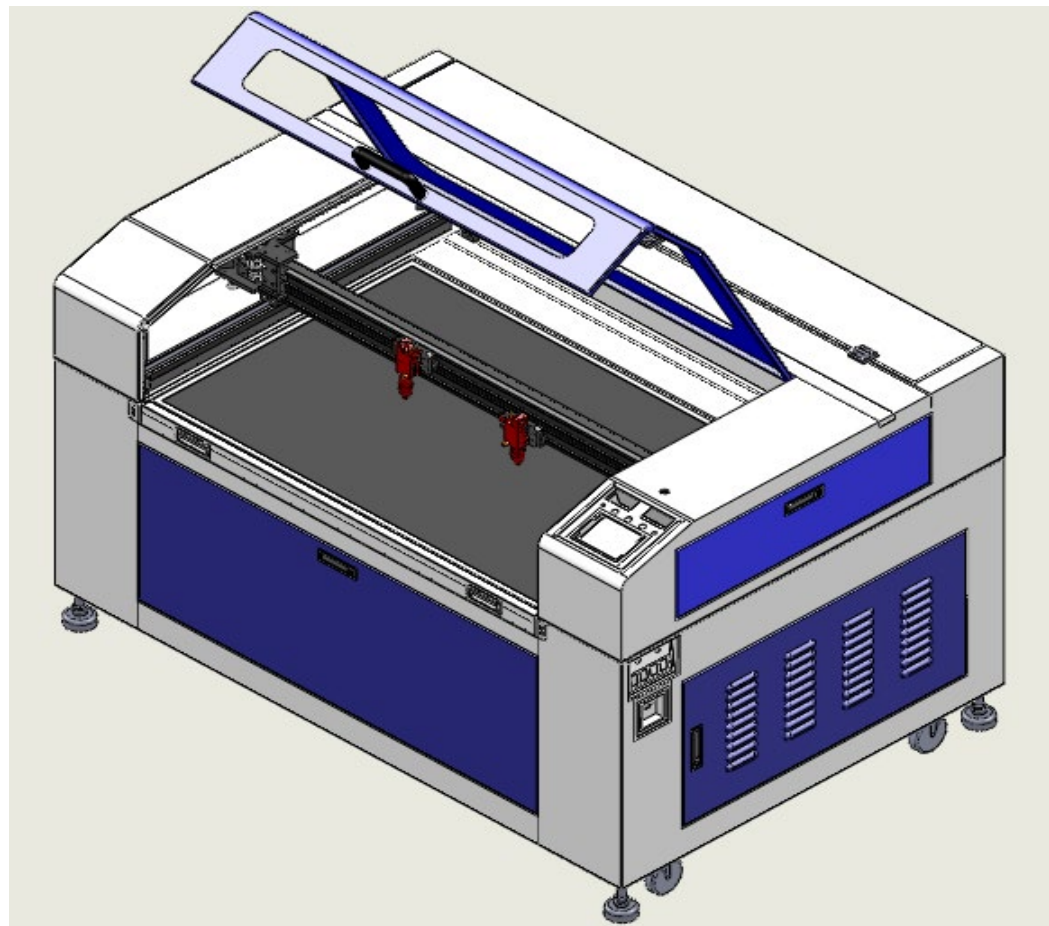

Fig. 3-1 External View of GN-series Machine

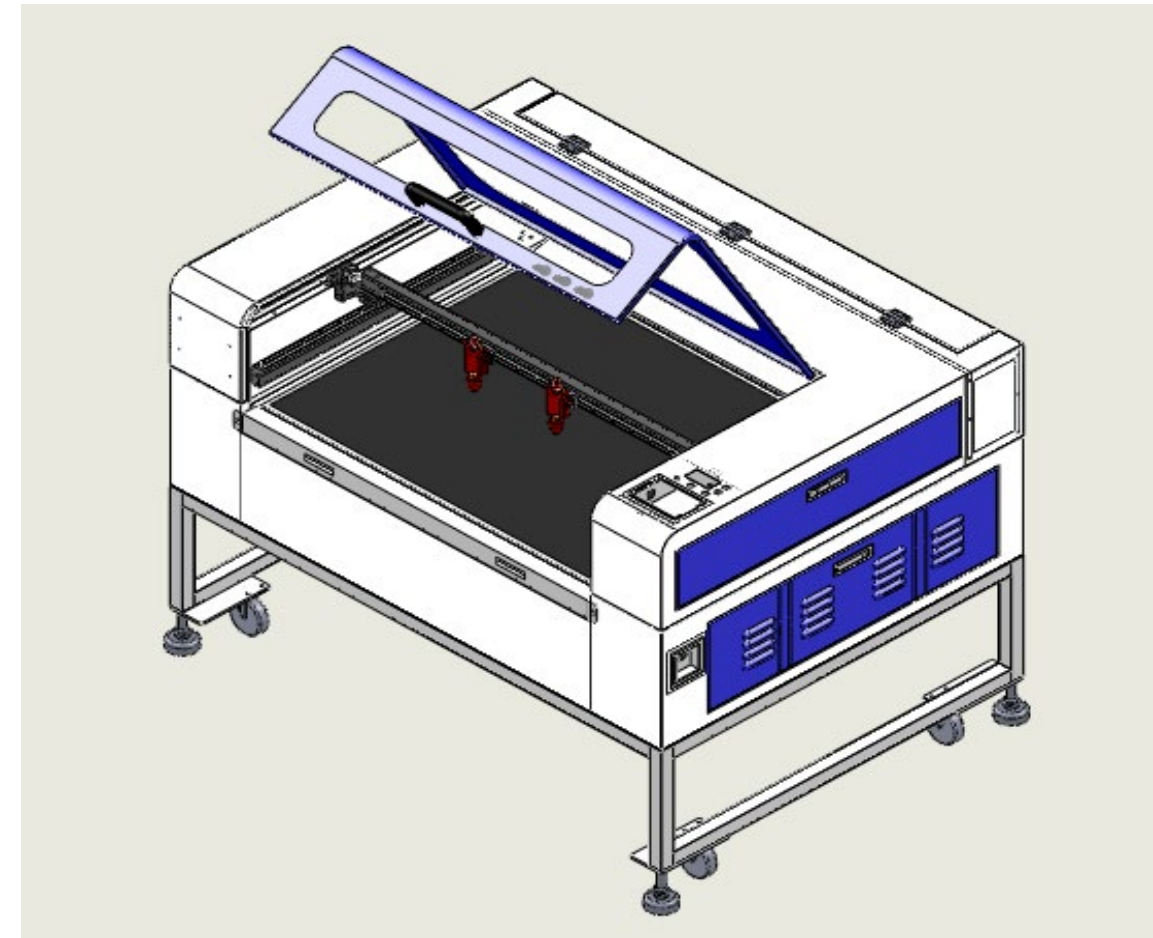
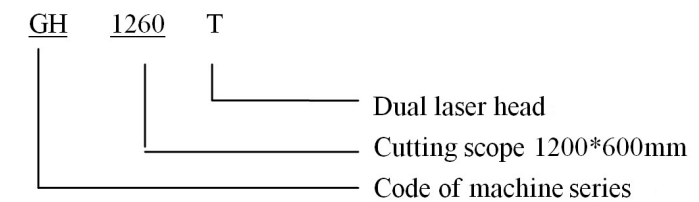

Fig. 3-2 External View of GH/D1210-series Machine

### 3.3 Model instruction

Model instruction:



### 3.4 Main application and scope of application

GN/GH/D1210 series machine belongs to CO<sub>2</sub> non-metal cutting and engraving machine which can be used for cutting multiple non-metal materials including: wooden products, papers, cloth, leather, epoxy resin, PMMA, unsaturated polyester resin and plastic. Provided with auxiliary gas O<sub>2</sub>, the D1210 series machine can cut stainless steel and carbon steel with thickness less than 1mm.

### 3.5 Operation environment

This equipment is designed according to related industrial environmental rules and the Company

is not liable for any losses of equipment that is installed in improper environment (such as a residence).

Please use the equipment in the suggested environment to avoid damaging equipment or reducing its service life.

Suggested operation environment:

<b>Ambient temperature</b>	10°C -30°C
<b>Ambient temperature for transportation and packaging</b>	5°C - 45 °C
<b>Relative humidity</b>	30% - 80%
<b>Power supply</b>	Single phase 220VAC,50HZ/60HZ,10A-20A
<b>Fluctuation of power grid</b>	< ±5%
<b>Ground wire of power grid</b>	Complying with the national standard of machine room

The equipment shall not be installed in any of the following places:

- Place with excessive garbage, dust and oil mist.
- Place with vibration and a lot of severe impacts.
- Place which is close to medicine and flammable and explosive articles.
- Place which is close to high-frequency interference source.
- Place where condensation may easily occur.
- Environment with high concentration of CO<sub>2</sub>, NO<sub>x</sub>, and SO<sub>x</sub>.

### 3.6 Impact on environment and energy

Provided with a CO<sub>2</sub> laser source, the equipment is engaged in the contact/non-contact processing and thus may cause noise, chemicals (limited by processing materials), dust and air pollution during processing.

### 3.7 Working principle

GN/GH/D1210 series laser cutting machine is composed of control system, optical system, XY moving system, workbench and water cooling system. The CO<sub>2</sub> laser may output laser with wavelength varying from 10.55μm to 10.63μm; fine and high-energy density laser spot is formed through laser mouth after the laser is reflected by reflecting mirror, focused through focus lamp and it can puncture the surface of workpiece and form small holes on it; these small holes can be arranged by controlling XY motion to form corresponding shapes and achieve the purpose of cutting objects.

#### 3.7.1 Control system (see operation instruction of control system)

#### 3.7.2 Host module

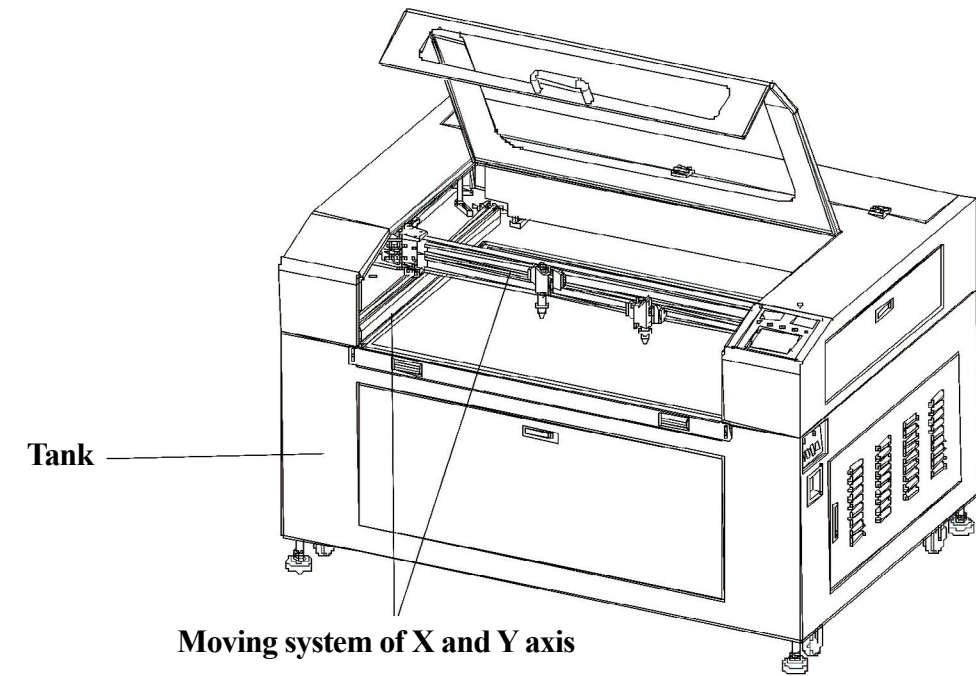

Fig. 3-3 GN

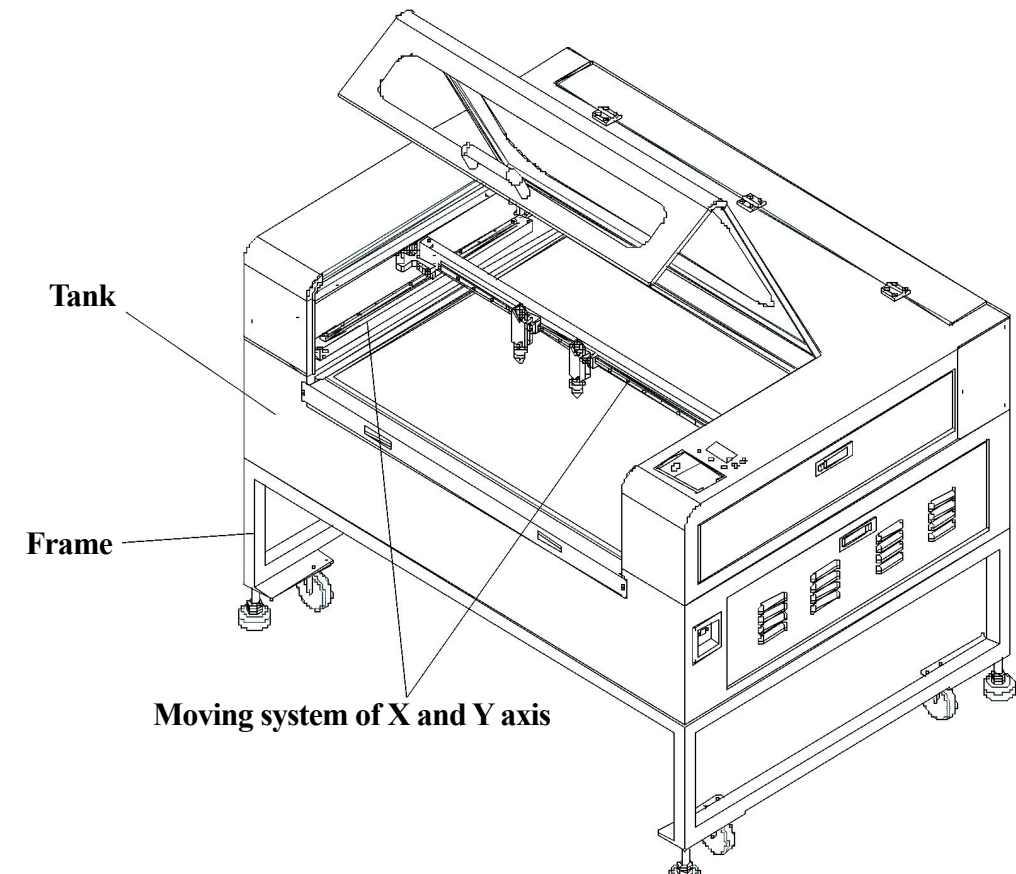

Fig. 3-4 GH /D1210 Series



### 3.7.3 Optical system

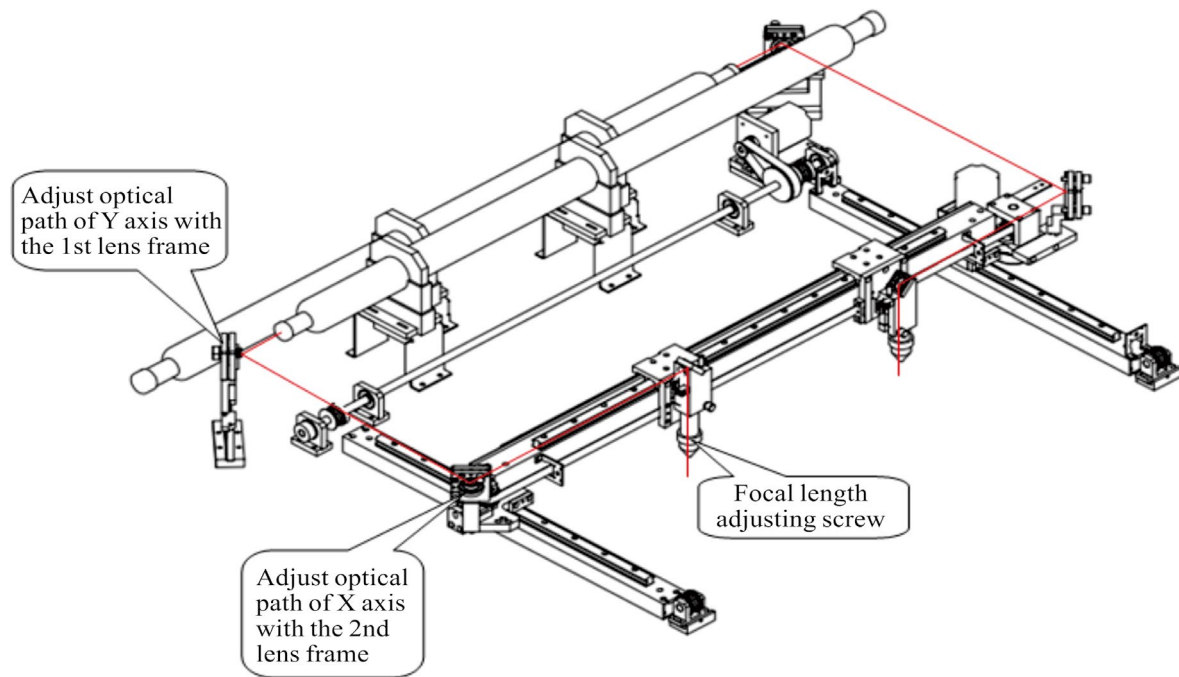

Fig. 3-5 Principle of Optical Path

### 3.7.4 Workbench

Workbench of standard honeycomb panel, and cutter strip workbench can be provided.

### 3.7.5 Exhaust system

The main part is fan, see figure below:

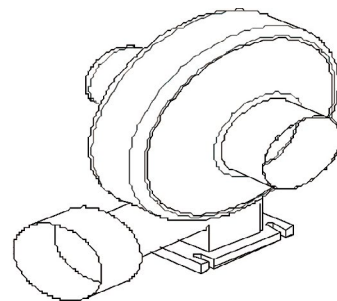

Fig. 3-6 Fan

A lot of smoke or harmful gas will be generated at the surface of processed materials during laser processing and they must be discharged to outdoors through a fan and air hose.

### 3.7.6 Cooling system: (see figure below)

Provided with multi-stage centrifugal circulating pump and PVC connecting pipe, the cooling water tank is rust- and corrosion-free and can use pure water directly. The machine also has a high-pressure pure water filter device to guarantee smoothness of pipelines and operational safety of the laser device.

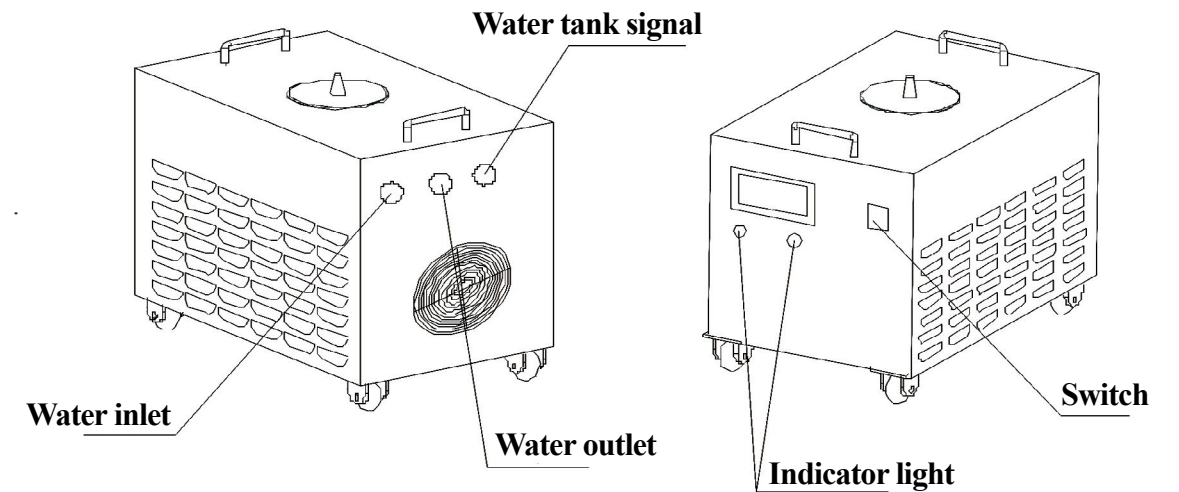

Fig. 3-7 Water Tank

## Chapter 4 Installation and Debugging

### 4.1 Delivery inspection

We always bear in mind the interest of our customers. There may be unsatisfactory conditions after customer receives machine due to other reasons, and the customer shall inspect the machines one by one according to packing list to see if the parts and accessories of machine are missing or damaged during packing and transportation. In such cases, please contact the Company quickly (including authorized agent of the Company) and we will solve it as soon as possible.

#### 4.1.1 Precautions of unpacking

Please inspect the machines one by one according to packing list to see if the parts and accessories of machine are lost or damaged during packing and transportation. In such cases, please contact the Company quickly (including authorized agent of the Company) and we will solve it as soon as possible.

If the devices listed in packing list are intact and in good conditions, please fill out warranty bills accurately and send to the Company or authorized agent as soon as possible for building customer files

and preparing for further service and work.

### 4.1.2 Inspection content

Please check the appearance and performance of all parts and accessories of machine according to packing list.

## 4.2 Requirements of installation environment

The machine shall be used in places without sharp changes in temperature. It shall not be installed and used in:

place with excessive garbage, dust and oil mist.

place with vibration and a lot of severe impacts.

place which is close to medicine and flammable and explosive articles.

place which is close to high-frequency interference source.

place where condensation may easily occur.

Environment with high concentration of CO<sub>2</sub>, NO<sub>x</sub>, and SO<sub>x</sub>.

Sharp changes in ambient temperature shall be avoided since there will be condensation, dirt and mist spot occurring on optical lens. If such changes are unavoidable, the equipment shall be used after there is no condensation.

The machine shall be installed vibration-free environment horizontally and provided with some spacing. It shall be installed in a place where there is compressed air and easy exhausting for the sake of convenience.

## 4.3 Installation method and precautions

### 4.3.1 Leveling

Fasten the caster and lift the machine leg after the machine is installed on the proper place on flat ground, and the machine legs shall all contact the installation ground. Carry out leveling of machine through 4 machine legs and inspect the level of machine through level gauge.

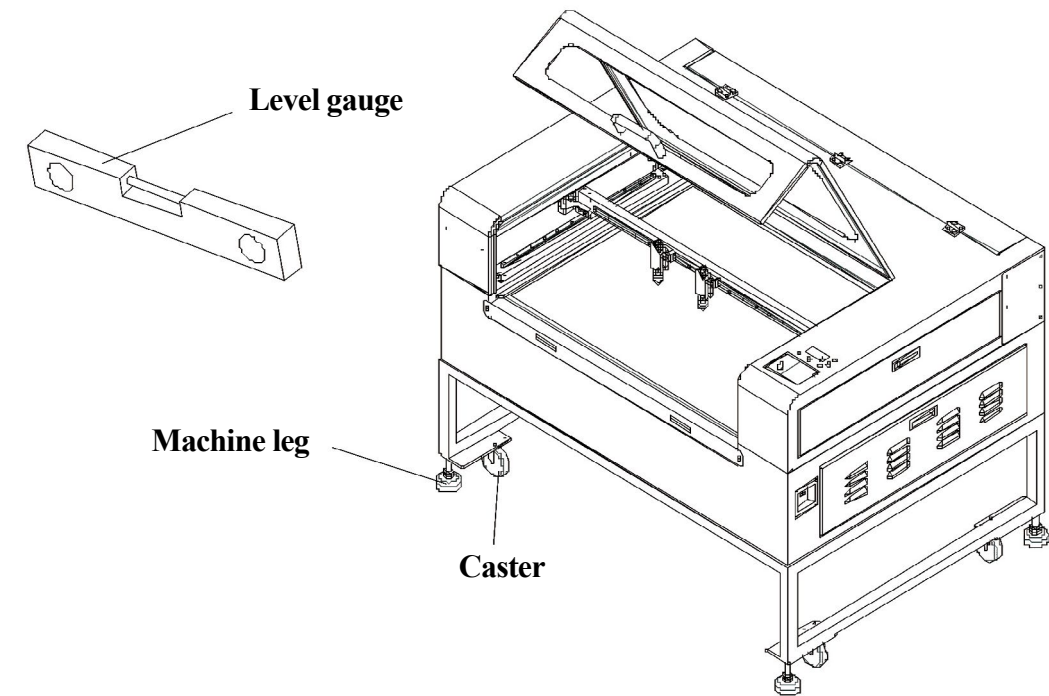

Fig. 4-1 Leveling

### 4.3.2 Connection of water tank

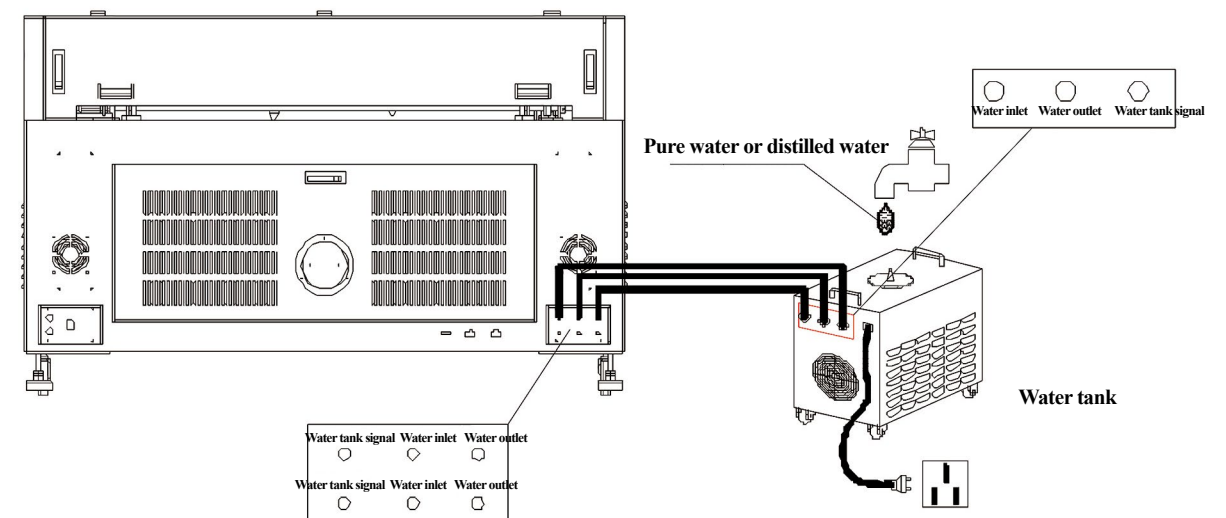

Fig. 4-2 Connection of Water Tank

### 4.3.3 Connection of fan/power cord

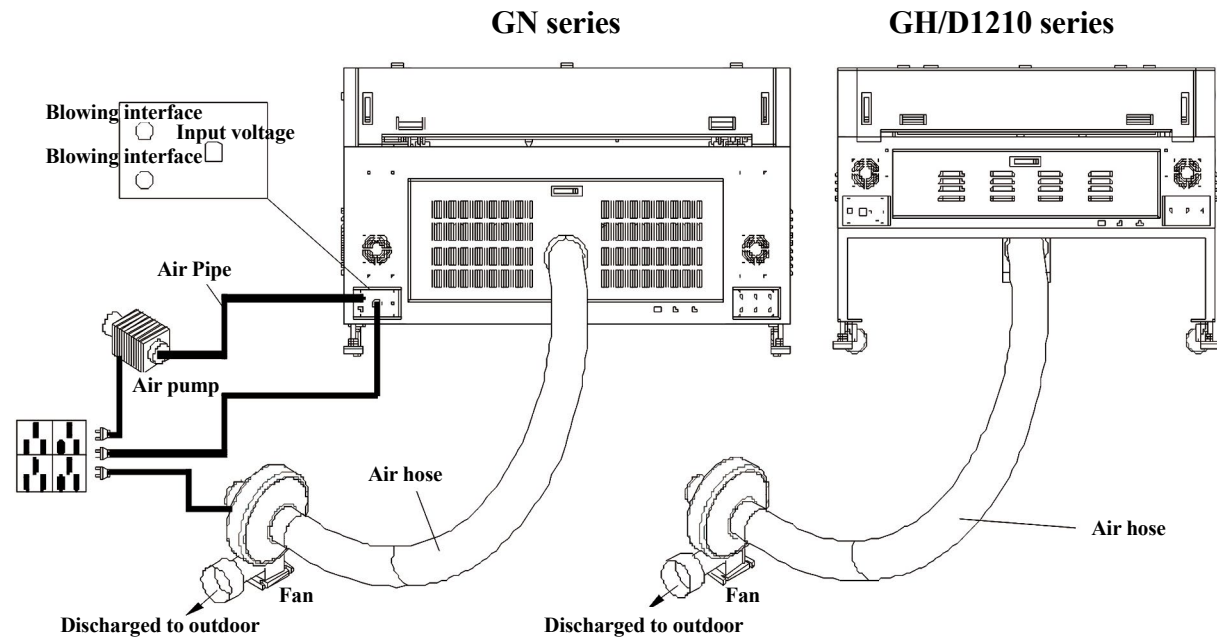

Fig. 4-3 Connection of Fan/Power Cord

#### 4.4 Debugging method and precautions

Put a white paper on workbench and adjust the height according to the distance between the paper and laser mouth. Then press Test button in electric control cabinet and the laser will mark on materials. Adjust the height of vibration lens manually and press Test button to mark on materials again and compare the sizes of two marks. Repeat the height adjusting and marking procedures until the size is the smallest. This is the focal position.

Tool: one set of Allen wrenches



Attention

Check if auxiliary gas and focal lens are normal before debugging.

Test button is used to trigger laser and can not be pressed for a long time.

## Chapter 5 Notice for Use

#### 5.1 Preparation and inspection before usage

1. Water cooling system: the user shall fill the water tank with pure water (distilled water is recommended) and check if the water tank and connecting water pipes are subject to water leakage.
2. Power supply: check if 220V power supply is connected and if the interface is loose.
3. Air source: the air pipe of air pump/compressed air shall be connected with machine.

4. Exhaust system: debugging may be implemented after the connection of fan/air pipe is confirmed to be correct and smoke can be discharged outdoors.

#### 5.2 Startup program of machine

1. Ensure safe connection of power supply.
2. Turn on main power
3. Turn on power of water tank
4. Turn on air pump and fan
5. Press Power button

#### 5.3 Shutdown sequence of machine

1. Press Shutdown button
2. Turn off air pump and fan
3. Turn off power of water tank
4. Turn off main power

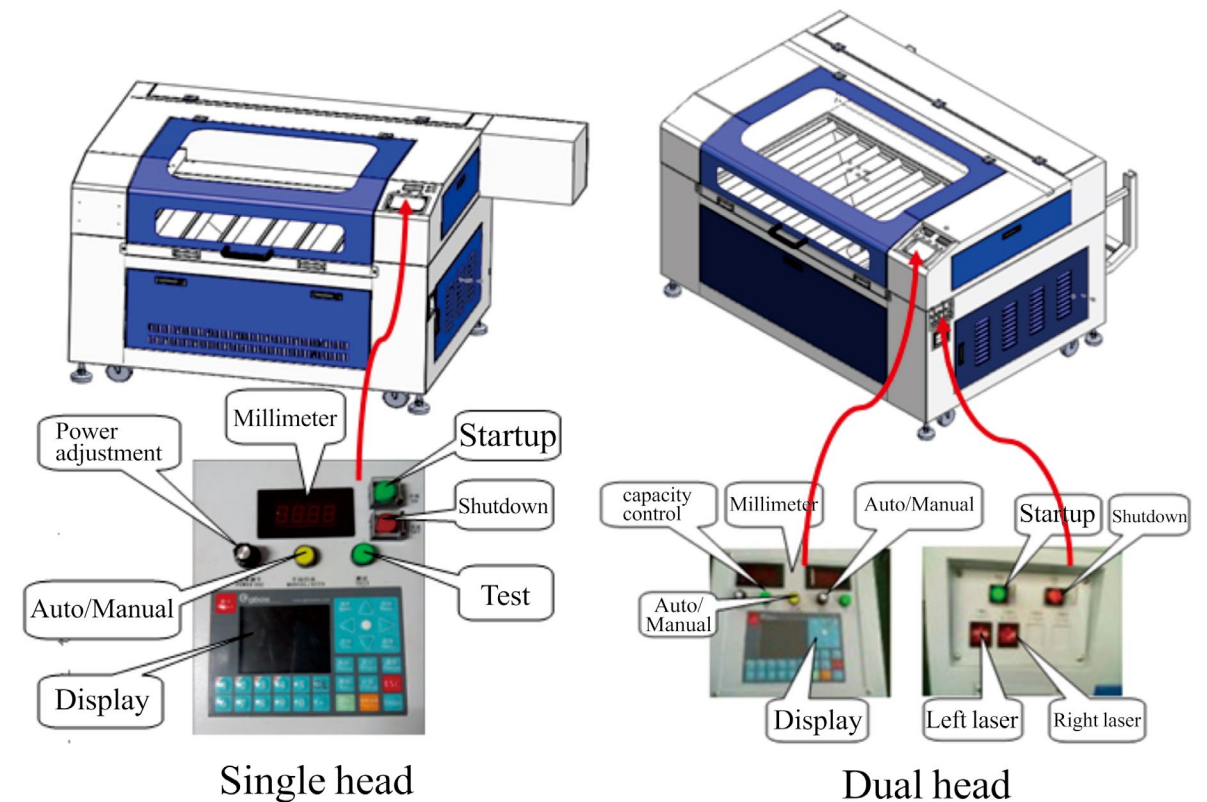

Fig. 5-1 Procedures of Startup and Shutdown



## Chapter 6 Maintenance and Troubleshooting

Some daily and regular maintenance is indispensable in order to ensure and extend service life of machine. Please formulate daily maintenance plan according to your particular circumstances.

### 6.1 Overview

Maintenance refers to appearance maintenance and regular and irregular maintenance of suction fan, optical system, cooling system, laser protection device and electrical system.

### 6.2 Daily maintenance

First, clean surroundings of machine to make ground dust-free and clean after each shift finishes work. Then clean the equipment including external surface of main control cabinet, housing of optical system, and surface of working table, making them sundries-free, dust-free and clean.

#### 6.2.1 Checking and maintenance for suction fan

Clean suction opening, suction fan and sundries inside air hose at least once a week, check if air hose of suction fan is bended and ensure good ventilation effect.

#### 6.2.2 Checking and cleaning for optical system

Be careful that lens is damaged and polluted when optical lens is stored and installed. The working lens shall be cleaned regularly (they shall be checked regularly on weekly basis, if necessary, they shall be cleaned), if not, service cycle of lens will be reduced.

Surface of workpieces will release lots of gases and splashes during laser cutting, welding and heat treatment for materials, and these gases and splashes will damage the lens. This damage will be produced by thermal lens effect resulting from pollutants' absorbing energy from laser beam when pollutants drop onto surface of lens. The user often shall check if the lens is polluted and clean often.

The correct cleaning method:

Cleaning for lens is only aiming to remove pollutants on lens. Be careful to avoid further pollution and damage to lens.

Step 1: Use air ball to blow away fine particles on surface.



Note

Never use compressed air, as there are oil and water drops in the air that will pollute lens further.

Step 2: Use absolute ethyl alcohol to clean lens slightly. Clean lens with a swab or lens wiping paper having dipping into absolute ethyl alcohol and wipe in a circular motion.

Use vinegar to clean if absolute ethyl alcohol fails to clean completely. This kind of cleaning employs acid to dissolve and revolve pollutants, but it will damage optical lenses. The vinegar can be

experiment – graded (50% dilution intensity) or household white vinegar (6% acetic acid). The process for this kind of cleaning is the same with that of absolute ethyl alcohol. Remove vinegar using absolute ethyl alcohol and dry the lens after cleaning.



Note

Excellent performance can be recovered through replacing lens if pollutants and damage fail to be removed through cleaning especially for burns to film resulted from metal splashes and dirt.

#### 6.2.3 Checking and maintenance for water tank

Checking before starting the machine:

PM: Check if power socket contacts securely and if working voltage is steady and normal

QM: Check if there is enough water in water tank

RM: Check if water inlet/outlet is connected normally and there is no loose and leaking situations, and check if the flow is unimpeded and unblocked

SM: Check if setting of water temperature is too high (20-30 °C for normal temperature)

Maintenance:

1. Change water regularly (using pure or distilled water)
2. Clean filter screen for wind inlet/outlet on daily basis



Note

1. Do not operate without water. Make sure laser tube is filled with circulating water before operating the machine
2. Fan will rotate after reaching a certain temperature during heat dissipation of water tank
3. Make sure wind channel of water tank is unblocked. Keep at least 30 CM distance between wind inlet/outlet behind water tank
4. It is suggested to heighten setting of water temperature or adjust it to about 10 °C if condensate water is produced when water temperature is lower than environmental water.

#### 6.2.4 Electrical checking

Please regularly clean dust in electrical control cabinet and check if circuits are loosed, dropped or eaten by rodent. Check working condition of each exhaust fan.

#### 6.2.5 Checking for laser protection device

Please regularly check if laser enable switch, air and flow pressure protection switches are in normal condition.

### 6.2.6 Repair cycle

Please formulate repair plan to conduct corresponding repair according to your requirements.

## 6.3 Fault analysis and troubleshooting method

### 6.3.1 Weak laser energy.

Reasons:

- There is offset of optical path.
- there are pollutants on lens.
- the lens are damaged.
- laser device is aging.

Checking methods:

- Check if incident light of each lens is in the center of lens.
- Check if lens (focus lens, reflector and beam combiner) is cleaned.
- Check if lens (focus lens, reflector and beam combiner) is damaged.
- Test power of laser at outlet of laser device directly.

Treatment methods:

- Adjust optical path (for method, please see Adjusting method 4.5).
- Use swab, lens wiping paper or absolute ethyl alcohol to wipe lens (for method, please see Checking and cleaning for optical system 7.2.2).
- Change damaged lens.
- Change laser device.

### 6.3.2 No light in operation during normality in testing.

Reason:

Processing parameter is incorrect.

Checking method:

Check the setting of processing power.

Treatment method:

Reset processing parameters.

### 6.3.3 No light both in operation and testing

Reasons:

- There is offset of optical path.
- Laser switch fails to open.
- Laser switch is damaged or connecting lines contact poorly.
- Laser device or its power supply is damaged.

Checking methods:

- Check if incident light of each lens is in the center of lens.
- Check if laser enable switch enables indicator lamp lit.
- Check input and output signal of control card, check if connecting lines of laser device is normal and if connection between laser power and laser device is normal.
- Check is indicator lamp of laser power is lit.

Treatment methods:

- Adjust optical path.
- Open laser enable switch.
- Reconnect connecting lines.
- Change insurance of laser power and laser power.

### 6.3.4 Machine fails to operate in one or multiple directions.

Reasons:

- Servo motor gives an alarm.
- Connecting lines of limit switch contact badly.
- Pollutants cover or damage limit switch.
- Control card, driver and motor fault.

Checking methods:

- Check corresponding alarm code.
- Checking connecting lines between corresponding limit switch and control card.
- Check if pollutants cover limit switch and if there is corresponding change when limit switch is covered or not.
- Check connecting lines of control card, motor and driver.

Treatment methods:

- Pointedly handle corresponding code fault.
- Reconnect connecting lines between limit switch and control card.
- Clean pollutants and Change limit switch.
- Reconnect connecting lines of control card, motor and driver.

### 6.3.5 The machine is not energized

Reasons:

- Power lines contact poorly.
- Emergency stop switch is locked.
- Connecting lines between start button and contactor fault.
- Start button or contactor faults.

Checking methods:

- a. Check power supply and power connecting lines.
- b. Check state of emergency stop switch.
- c. Check if connecting lines between start button and contactor fault.
- d. Check the start button or contactor.

Treatment methods:

- a. Reconnect power lines.
- b. Open emergency stop switch.
- c. Reconnect faulted connecting lines between start button and contactor.
- d. Change the start button or contactor.

### 6.3.6 Tracks of machine operation have obvious sawteeth

Reasons:

- Settings of operation speed and acceleration are too high.
- Wires connecting driver and motor fault.
- Motor is damaged.
- There are loose set screws in moving part.

Checking methods:

- a. Check settings of movement speed and acceleration (cutting speed  $\leq 9,000$  mm/min and increasing speed grade).
- b. Check connection of driver and motor wires.
- c. Check motor.
- d. Check if screws are fixed in moving part.

Treatment methods:

- a. Reset movement speed and acceleration.
- b. Reconnect wires of driver and motor.
- c. Change motor.
- d. Fix screws on each guide rail;

Do disconnect power during searching/eliminating line fault. Never work before eliminating all machine faults.

## Chapter 7 Technical Specification

This chapter lists main functions, specifications, parameters, etc.

I. Parameters of GN/GH/D1210 series laser machine are as follows:

Model	GN/GH/D1210
Type of laser device	Domestic laser tube (glass)
Cooling method	Water cooling
Processing method	Plane
Laser power	70W-180W optional
Laser wavelength	10.6um
Minimum line width	0.15mm
Processing line speed	$\leq 300$ mm/s
Accuracy of relocating	$\pm 0.05$ mm
Engraving depth	$\leq 5$ mm
Minimum character	1mm

The parameters above are applicable to GN/GH/D1210 series machines

II. Basic parameters of GN/GH/D1210 model

Model	Processing scope (mm)	Dimensions (mm)	Weight (Kg)	Power supply
GN640	600*400	1120*760*970	170	220V 50Hz/60Hz 10Amax
GN1080	1000*800	1450*1090*970	220	220V 50Hz/60Hz 10Amax
GN1280T	1200*800	1850*1250*1000	300	220V 50Hz/60Hz 10Amax
D1210	1200*1000	1900*1530*1027	220	220V 50Hz/60Hz 10Amax
GH750	700*500	1250*900*970	160	220V 50Hz/60Hz 10Amax
GH960	900*600	1460*1000*970	190	220V 50Hz/60Hz 10Amax
GH1080	1000*800	1560*1150*982	220	220V 50Hz/60Hz 10Amax
GH1260T	1200*600	1790*1150*1006	280	220V 50Hz/60Hz 10Amax
GH1280T	1200*800	1900*1420*1006	300	220V 50Hz/60Hz 10Amax
GH1480T	1400*800	2100*1300*1006	325	220V 50Hz/60Hz 10Amax
GH1610T	1600*1000	2300*1530*1007	380	220V 50Hz/60Hz 10Amax
GH1810T	1800*1000	2420*1530*1006	400	220V 50Hz/60Hz 10Amax

The parameters above are for reference only; Gbos reserved the right of final explanation.